

# GELMI

ESPERIENZA PASSIONE COMPETENZA



Catalogo 2021





Ogni prodotto in questo catalogo è contrassegnato con delle icone, che ne contraddistinguono le caratteristiche di produzione. Questi sono i significati:

The following icons are used throughout this catalogue to highlight the key features of each product:

<p><b>100% Prodotto Italiano.</b> Per una garanzia di qualità e disponibilità nei tempi richiesti dal cliente.</p>		<p><b>100% Made in Italy.</b> A guarantee of the highest possible quality and availability for timely production and fast deliveries.</p>
<p><b>Stampa digitale.</b> Stampato in digitale ad altissima risoluzione in quadricromia.</p>		<p><b>Digital printing.</b> High-resolution coloured digital print from dye sublimation with four-colour resolution.</p>
<p><b>Strutture su misura.</b> Realizzate interamente all'interno delle nostre officine per soddisfare ogni esigenza.</p>		<p><b>Customizable structures.</b> Designed and manufactured internally in our in house workshop. Gives us the flexibility to adapt to each individual customers' requirements.</p>
<p><b>Tessuto H2O texo.</b> Tessuto nautico alta tenacità con trattamento idrorepellente, studiato per una lunga durata.</p>		<p><b>H2O texo.</b> Waterproof "nautico" fabric, developed to ensure long life.</p>
<p><b>Tessuto Relife.</b> Tessuto ecologico ottenuto dal riciclo del PET, a sua volta riciclabile.</p>		<p><b>Relife Textile.</b> Recyclable fabric made from recycled PET.</p>
<p><b>Tessuto HD TEX.</b> Innovativo tessuto coprente, evita l'effetto trasparenza per una maggiore visibilità dei loghi.</p>		<p><b>HD TEX fabric.</b> Innovative High Density fabric especially developed to avoid the transparency effect in order to enhance the visibility of printed logos.</p>
<p><b>Strutture Certificate.</b></p>		<p><b>Certified structures.</b></p>

l'azienda	4	the company
i nostri tessuti migliori	7	our best fabrics
tessuti RELIFE	8	RELIFE fabrics
striscioni	10	banners
bandiere	14	flags
stampa in grande formato	28	large format printing
allestimento eventi	30	events set-up
nastri in tnt	32	tnt tapes
pettorine	33	sports bibs
cornici	34	frames
rollup	38	roll ups
strutture pubblicitarie	40	advertising structures
GTent	50	GTent
sedie e tavoli	52	tables & chairs
ombrelloni personalizzati	55	customizable beach umbrellas
gonfiabili	56	inflatables
tappeti	62	mats
imbottiti	64	stuffed items
stendardi/poster	66	kakemono/posters
gadgets	67	gadgets
gallery	70	photo gallery

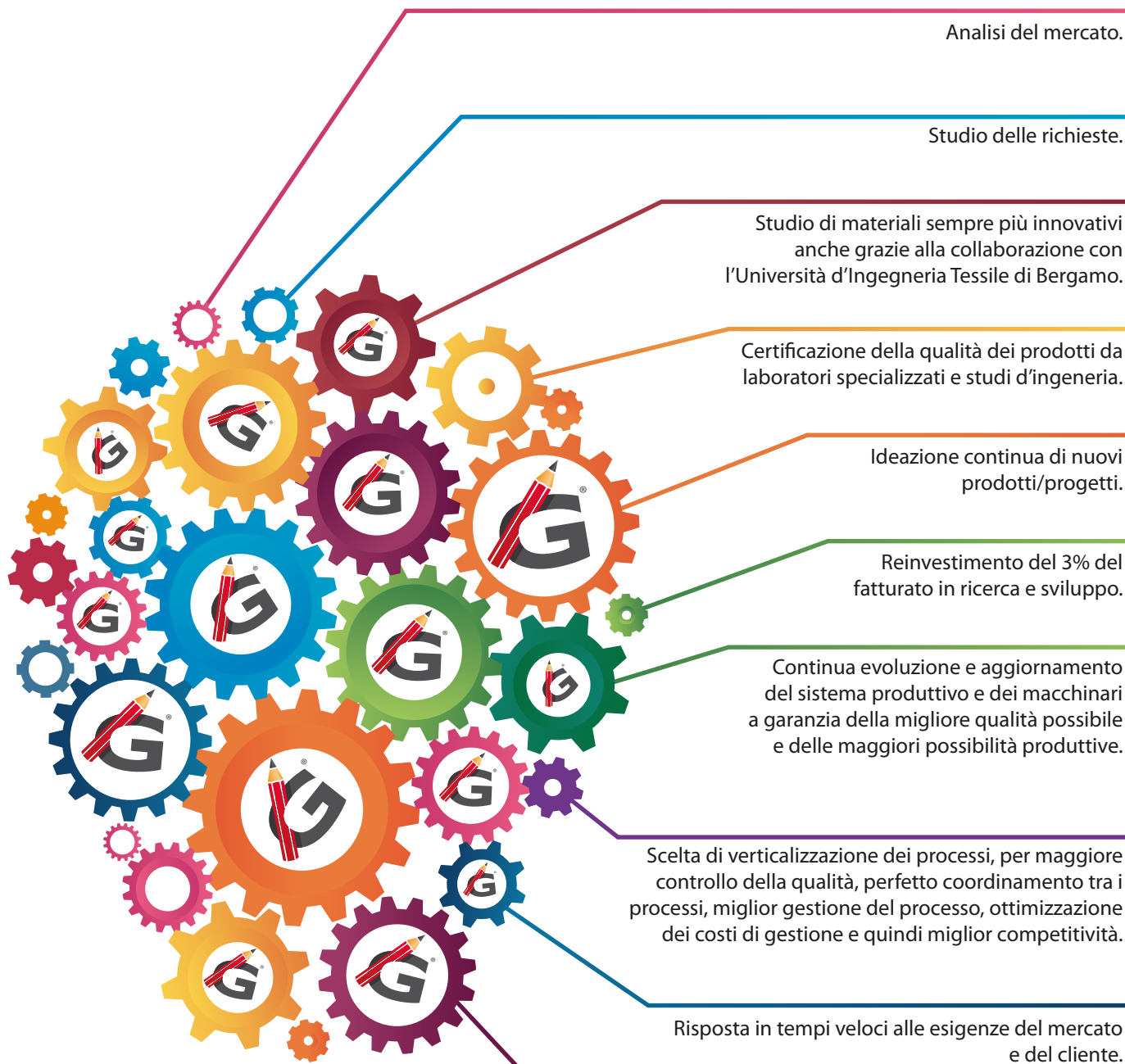

Analisi del mercato.

Studio delle richieste.

Studio di materiali sempre più innovativi anche grazie alla collaborazione con l'Università d'Ingegneria Tessile di Bergamo.

Certificazione della qualità dei prodotti da laboratori specializzati e studi d'ingegneria.

Ideazione continua di nuovi prodotti/progetti.

Reinvestimento del 3% del fatturato in ricerca e sviluppo.

Continua evoluzione e aggiornamento del sistema produttivo e dei macchinari a garanzia della migliore qualità possibile e delle maggiori possibilità produttive.

Scelta di verticalizzazione dei processi, per maggiore controllo della qualità, perfetto coordinamento tra i processi, miglior gestione del processo, ottimizzazione dei costi di gestione e quindi miglior competitività.

Risposta in tempi veloci alle esigenze del mercato e del cliente.

Staff preparato e impegnato nella soddisfazione del cliente, che è seguito passo passo dal progetto al prodotto consegnato!



- 25 addetti
- 2.400 clienti
- 5.000 ordini evasi nel 2020
- 6.500 strutture prodotte nel 2020
- 700.000 m<sup>2</sup> di tessuto stampato nel 2020
- 3.000 m<sup>2</sup> di superficie occupata per una gestione interna dell'intera filiera produttiva
- 7 plotter per stampa continua
- 3 calandre di fissaggio
- Officina meccanica per lavorazione strutture e alluminio
- Confezione sartoriale per realizzazioni su misura



Market analysis.

Feasibility studies.

Constant research and development of new and innovative materials in close collaboration with the Department of Textile Engineering of the University of Bergamo.

Product quality certification approved by specialized laboratories and engineering trials.

Constant development of new products and projects.

Re-investment of 3% of turnover in research and development.

Continuous development and optimization of production techniques and manufacturing equipment in order to guarantee the highest standards of quality and most efficient production processes.

Vertical manufacturing allows us greater quality control, perfect coordination and management of internal processes leading to the optimization of operating costs increasing competitiveness.

Fast reaction times to market trends and individual customer requirements.

Our highly committed and experienced staff are dedicated to delivering customer satisfaction with guidance through each stage of production from design to delivery.



25 employees  
2.400 customers  
5.000 orders processed in 2020  
6.500 structures produced in 2020  
700.000 sqm of textile printed in 2020  
3.000 sqm manufacturing facility allows us  
to internally manage the entire production process  
7 plotters for continuous printing  
3 fixing calanders  
Internal workshop for the production of aluminium structures  
In house sartorial finishing for ad hoc deigns

Nonostante questo brutto periodo, siamo ottimisti perché anche se non sappiamo quando, siamo sicuri che la ripartenza ci sarà e sarà super!

Noi siamo già pronti ai blocchi di partenza... aspettiamo solo il vostro VIA!

Intanto prepariamo tutte le **nostre novità** che questo periodo di maggiore tranquillità ci ha permesso di studiare al meglio!

**Progetto BE Defender:** studio e progettazione grazie a partnership di alto livello, di tessuti con trattamento antivirale contro Sars-Covid2 testati in laboratorio.

**Perché sulla salute non si scherza.**

**Progetto Eco Banner Relife e collezione tessuti Re life:** una collezione di tessuti studiati per il rispetto della natura, provenienti da materiale riciclato e a loro volta riciclabili.

**Perché allestire un ambiente vuol dire anche volergli bene.**

**Nuovi tessuti da noi ingegnerizzati:** abbiamo incrementato la collezione di tessuti da noi studiati e realizzati specifici per il mondo della comunicazione.

**Perché la nostra formazione tessile è una grande forza.**

**Pennoni per bandiere con certificazione:** le nostre strutture sono progettate da ingegneri che ne certificano la resistenza e sono realizzate internamente per la massima cura.

**Perché allestire con professionalità vuol dire proteggere i nostri clienti.**

**Stampa in tre metri:** con la stessa qualità di materiali e stampa proponiamo tessuti in altezza tre metri.

**Perché è sempre bello diventare grandi.**

**Sempre in collezione i nostri best seller** come bandiere, striscioni, gazebo, fondali, tappeti, gonfiabili e molto altro rinnovati nelle finiture, migliorati nei dettagli e nel packaging che potrete vedere in anteprima nel vostro ambiente grazie alla nostra App di realtà aumentata.

**Perché non si improvvisa sulla propria immagine.**

Affidati a dei veri professionisti! Sfrutta questi momenti per ripensare la tua immagine e trovare il supporto giusto per comunicarla. Affidaci una tua idea, un desiderio e noi studieremo il prodotto giusto per te nel rispetto del tuo budget!

**Solo da noi trovi tessitura, stampa, cucitura, confezione e officina per la creazione di strutture in una sola azienda.**

**Scegli a chi affidarti, scegli un professionista.**

Despite these challenging times, we remain optimistic for what the future holds. We are sure things will turn around for the best and when they do, the recovery will be great! We are ready and in position on the starting grid... we are just waiting for your GO! We chose to make the most of this unique moment in time and have dedicated ourselves tirelessly to perfecting our existing products and developing a whole range of exciting **new solutions** to keep up with ever evolving communication requirements.

**BE Defender project:** through intense research in collaboration with high-level partnerships, we have developed a range of lab tested fabrics with antiviral treatment specifically against Sars-Covid2.

**Because your health and wellbeing demand constant protection.**

**Eco Banner Relife project and Re life fabric collection:** a complete collection of fabrics purposely designed with the environment in mind, developed from recycled materials and in turn are recyclable after use.

**Because now you have the option to communicate in harmony with our precious environment.**

**Innovative fabric development:** we have expanded our collection of fabric offerings that are designed and manufactured directly by us to meet the specific demands that effective communication requires.

**Because textile expertise is our passion and strength.**

**Certified flagpoles:** our structures are designed by engineers who certify their strength and durability and are produced in-house to guarantee the highest quality standards.

**Because professional equipment means protecting customers.**

**Three meter printing:** with the same exacting high quality standards of materials and printing, we now offer fabrics in three-metre heights.

**Because bigger is better!**

**Our traditional best sellers** such as flags, banners, tents, backdrops, mats, inflatables and much more have all been updated and refined with new improved finishing details and packaging, which you can now preview in your own settings thanks to our innovative augmented reality app.

**Don't improvise with your communication!**

Trust the professionals! Take a moment to reflect upon and renew your image and find the best tools to communicate effectively. Entrust us with your ideas, your desires, and we will find the right solution for you within your budget!

**We have everything you need to communicate effectively and efficiently; we offer a one stop solution combining design, weaving, printing, sewing, tailoring together with a metal workshop to create everything you need under one roof. Choose carefully, choose a professional!**

## I NOSTRI TESSUTI MIGLIORI

OUR BEST FABRICS



### TESSUTO JACQUARD FILIGRANATO

**È la massima espressione di personalizzazione.**

Il logo è costruito all'interno della struttura del tessuto grazie a telai ad altissima precisione e ad un sistema di digitalizzazione del brand.

Successivamente il tessuto viene stampato in digitale sublimatico per la massima libertà di personalizzazione senza limiti di colore o dimensione.

**Il risultato finale è unico nel suo genere.**

### WATERMARKED JACQUARD FABRIC

**The ultimate expression of customization.**

The chosen logo is ingrained directly into the fabric itself through the digitalization of the logo by a high-precision chassis.

Subsequently, the fabric is printed using digital sublimation allowing complete freedom to customize regardless of colours or size.

**The end result is truly unique.**



ROLLUP



STENDARDI  
KAKEMONO

TOVAGLIA  
TABLECLOTH



### TESSUTO VELLUTO DI MICROFIBRA

Tessuto cangiante ideale per la realizzazione di cuscini, tovaglie, allestimenti di pregio.



### MICROFIBRE VELVET FABRIC

High quality velvet with a shimmering effect, ideal for cushions, tablecloths and other prestigious items.





# COLLEZIONE TESSUTI

## FABRICS COLLECTION



*Abbi a cuore il tuo mondo. Scegli*  *Noi mettiamo la plastica al posto giusto.*

 *è la nostra collezione di tessuti realizzata dal riciclo delle bottiglie di plastica con un risparmio energetico del 50% ed una riduzione di 3 kg di CO<sub>2</sub> ogni kg di PET.*

*Comunica responsabilmente, comunica*



*Take care of the world. Choose*  *We choose to put plastic in its right place.*

 *is our collection of fabrics made from recycled plastic bottles with an energy saving of 50% and a reduction of 3 kg of CO<sub>2</sub> for every kg of PET used.*

*Communicate responsibly, communicate*



# Il mondo è nelle nostre mani

*The world is in our hands*

*Quanto conta la sostenibilità*

*The cost of sustainability*

**1 Kg PET**

**PRODUCI**  
*PRODUCE*

**1 Kg di tessuto  
generato da PET**

*1 Kg of PET  
generated fabric*

**RISPARMI**  
*SAVE*

**3 Kg CO<sub>2</sub>**

*(Pari alle emissioni medie di  
un'automobile dopo 25 Km)*

*(The average emissions  
of a car travelling 25 Km)*

*Camminiamo insieme sulla strada della  
sostenibilità con i nostri tessuti a marchio*

*Let's walk together on the road to  
sustainability with our branded fabrics*



*Obiettivo 2020: 120.000 Kg di CO<sub>2</sub> risparmiati  
con circa 400.000 m<sup>2</sup> di tessuto generato da PET*

*Our target for 2020: 120,000 kg of CO<sub>2</sub> saved  
with around 400,000 m<sup>2</sup> of PET-generated fabrics*



**GUARDA COME RICICLIAMO**  
*SEE HERE HOW WE RECYCLE*

[www.bannerrelife.it](http://www.bannerrelife.it)





## TNT GOLD BANNER 120



Prodotto **rivoluzionario** nel mondo della comunicazione visiva, **proviene da materiale riciclato e a sua volta riciclabile**. Molto più resistente rispetto al TNT tradizionale. Vista la sua alta resistenza allo strappo può essere riutilizzato più volte.

A **revolutionary** product in the world of visual communication, **produced from recycled materials and importantly, it can be recycled after use**. Much stronger than traditional TNT. Thanks to its high tear strength it can be reused several times.

## GOLD BANNER 200



In risposta ad un mercato sempre più attento all'ecologia, proponiamo lo striscione Gold Banner 200.

Rispetto all'ormai superato PVC, il nostro Gold Banner 200 è:

- **Ecologico**
- **Riciclabile**
- Ecocompatibile
- Leggero
- Pratico
- Resistente
- Economico

In response to an increasingly eco-friendly conscious market, we offer Gold Banner 200.

Compared to obsolete PVC banners, our Gold Banner 200 is:

- **Ecological**
- **Recyclable**
- Environmentally friendly
- Lightweight
- Practical
- Strong
- Economical

# GOLD BANNER FIRE RESISTANT



## Striscioni in tessuto Ignifugo classe 1.

Corredato da Certificato del Ministero degli Interni, Indispensabile per allestimenti indoor, per luoghi/ eventi pubblici e ogni situazione dove venga richiesta la massima sicurezza.

Resa cromatica di altissimo livello sia nei colori che nella qualità delle immagini.

## Banners in class 1 fireproof fabric.

Certified by the Italian Ministry of the Interior, essential for use in indoor locations or during public events where maximum security is required.

Allows the rendering of colours and image definition of the highest quality.



## POLYMESH



### **POLYMESH è il miglior striscione pubblicitario antivento per esterno.**

La sua particolare costruzione microforata lo rende adatto ad ogni condizione climatica, garantendo il passaggio dell'aria ed evitando il pericoloso e antiestetico effetto vela.

**Già pronto all'uso, basta inserire le fascette nei fori del tessuto.**

### **POLYMESH is the best outdoor advertising banner for windy conditions.**

*Its special micro-perforated design makes it perfect for all weather conditions allowing air to pass through it avoiding the dangerous and unaesthetic sail effect.*

**Easy to use, simply pass cable ties through the holes in the fabric to secure the banner.**

## STARTEX



### **Resistenza allo strappo superiore agli striscioni in pvc.**

Eccezionale **rigidità** del tessuto per un facile allestimento senza pieghe.

Massima resistenza allo strappo anche senza occhielli.

**Ideale per allestimenti di lunga durata.**

### **Greater tear resistance than traditional pvc banners.**

*Great fabric **stiffness** for easy set-up without creases.*

*High tear resistance even without eyelets.*

**Ideal for long-term installations.**



# TNT ART.135



## OTTIMA RESISTENZA ALLO STRAPPO

Carichi di rottura:  
carico massimo longitudinale - N/5 cm 250  
carico massimo trasversale - N/5 cm 150

## EXCELLENT TEAR RESISTANCE

Tensile strength:  
maximum longitudinal load - N/5 cm 250  
maximum transversal load - N/5 cm 150

### Indispensabile per tutti i tipi di comunicazione!

Senza costi di impianti stampa.  
Senza quantità minime.  
Senza limiti di colore o sfumature.  
Elevata resistenza allo strappo.

**MIGLIOR RAPPORTO QUALITÀ / PREZZO!**

### Ideal for all kinds of communication!

No screen printing costs.  
No minimum quantities.  
Unlimited colours and designs.  
High tear resistance.

**BEST QUALITY / PRICE RATIO!**

## SISTEMI DI FISSAGGIO

FIXING SYSTEMS

### OCCHIELLI

EYELETS



### BORDO FINESTRATO

PERFORATED SEAM



## INDISPENSABILI

ESSENTIAL

### FASCETTE

CABLE TIES

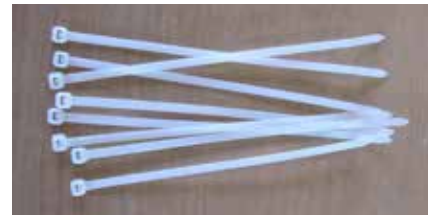

## CONFEZIONE

PACKAGING



**BOBINA**  
ROLL



**IMBUSTO**  
SINGOLO  
INDIVIDUALLY  
WRAPPED

**DAI NOSTRI LABORATORI  
DI RICERCA IL NUOVO  
TESSUTO PER BANDIERE**

**FROM OUR  
RESEARCH LABS  
THE NEW FLAG FABRIC**

**HD TEX**

tessuto nautico  
"nautico" fabric



Effetto trasparenza  
del classico  
tessuto nautico

Transparency effect  
of traditional  
nautical fabric

0% Effetto trasparenza  
100% Passaggio del colore  
Elevata resistenza allo strappo

0% Transparency effect  
100% Colour transition  
High tear resistance

ALTA DENSITÀ DI TESSITURA  
CON 9 KM DI FILATO  
SI REALIZZA 1 m<sup>2</sup> DI TESSUTO

HIGH WEAVE DENSITY  
9 KM OF THREAD  
TO PRODUCE 1 m<sup>2</sup> OF FABRIC

**NOVITA' 2020**  
Disbonibilità tessuto IGNIFUGO

**NEW FOR 2020**  
Now also available in FIREPROOF fabric



## L'UNICA BANDIERA A LUNGA DURATA THE ONLY LONG-LASTING FLAG

### IMPERMEABILE GRAZIE AL SUO INNOVATIVO TESSUTO H2O PROOF

Non si appesantisce e sventola meglio limitando l'effetto frusta che logora la bandiera, inoltre non assorbe le piogge acide che ledono le fibre del tessuto.

Disponibile anche con tessuto .

### WATERPROOF THANKS TO THE USE OF INNOVATIVE H2O PROOF TEXTILES

No water absorption avoids damage and ripping of the flag due to increased weight combined with a fluttering effect. Furthermore, the fabric does not absorb acid rain which degrades the fibers.

Also available with  fabric.



### LAVORATA CON TAGLIO LASERIZZATO

Studiato per non indebolire il lato maggiormente esposto al vento. **Le bandiere tradizionali iniziano a rompersi nel loro punto critico**, cioè sul lato opposto al palo, con il distaccarsi dell'orlo. Con il taglio laserizzato si evita questo problema.

### LASER CUT FINISHING

Developed to avoid the weakening of the windward side of the flag. **Traditional flags tend to tear at their critical points**, in particular at the hem on the windward side. With a laser cut we avoid this problem completely.



GFlag si presenta con una confezione sartoriale curata nei minimi dettagli per adattarsi ad ogni pennone.

GFlag offers sartorial level finishing with great attention to detail in order to perfectly fit each and every flagpole.





## TESSUTO TRAFORATO

PERFORATED FABRIC



Tessuto Traforato, 100% poliestere, peso 120 gr/m<sup>2</sup>, realizzato con filati selezionati. Si possono realizzare bandiere, maxiteli pubblicitari e adatto a situazioni ventose in quanto limita l'effetto vela. **Disponibile anche nella versione relife.**

*Perforated fabric, 100% polyester, weight 120 gr/m<sup>2</sup>, made from selected yarns. Used for the production of flags, extra large banners and ideal for windy conditions as it limits the sail effect. **Also available in relife version.***

## TESSUTO NAUTICO

NAUTICAL FABRIC

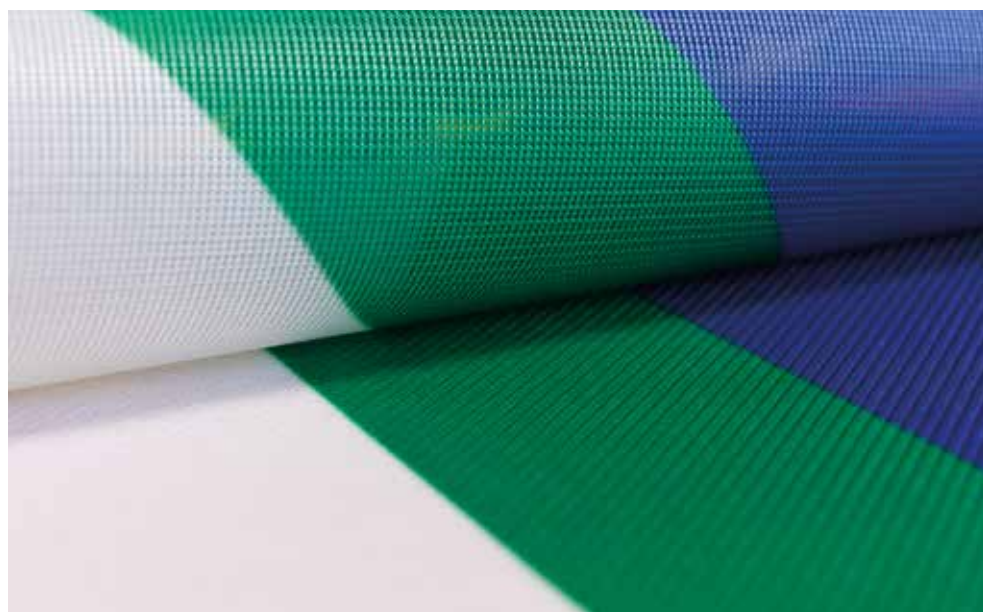

Tessuto tradizionale utilizzato per la realizzazione delle bandiere, 100% poliestere, peso 110 gr/m<sup>2</sup>, adatto per prodotti economici e bandierine per evento. **Disponibile anche nella versione ignifuga o relife.**

*The traditional fabric used for the production of flags, 100% polyester, weight 110 gr /m<sup>2</sup>, suitable for economical products and event flags. **Also available in both fireproof and relife versions.***

## REALIZZAZIONI EXAMPLES

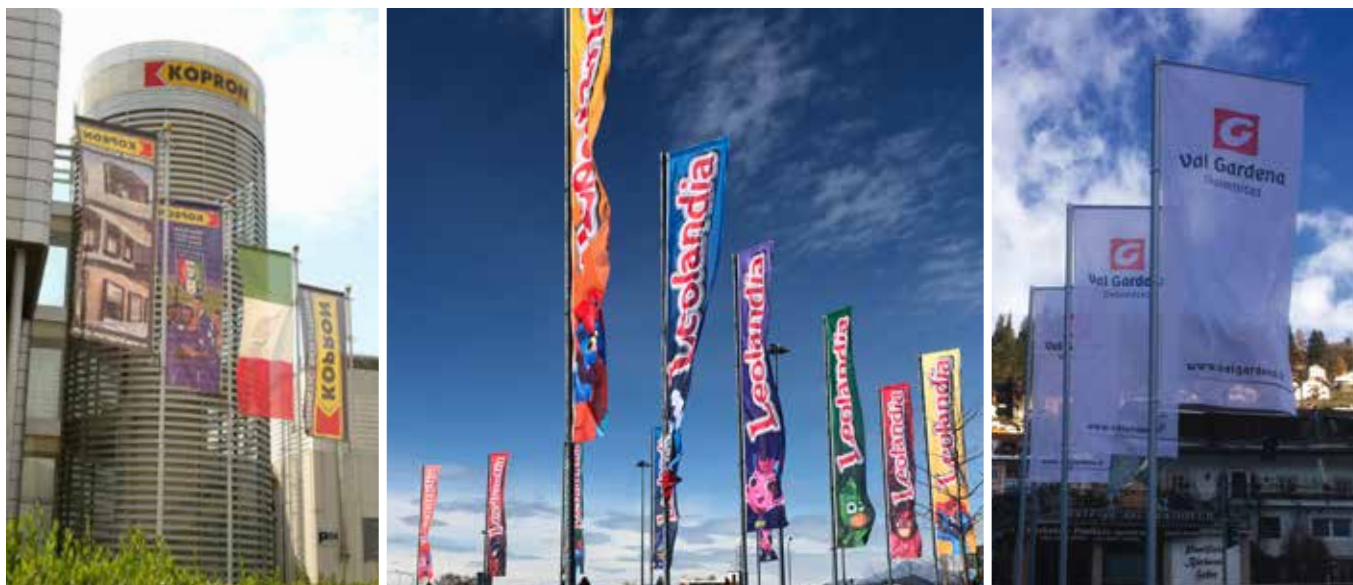

### BANDIERE ISTITUZIONALI

### INSTITUTIONAL FLAGS

Realizzazione bandiere di ogni nazione, regione, provincia, ente. Disponibili accessori quali aste, staffe, basamenti, puntali ed altro ancora. Disponibili anche in tessuto NAUTICO.



*Production of national, regional, provincial and institutional flags.*

*Available accessories include poles, brackets, stands, tips and more. Also available in NAUTICAL fabric.*

### BANDIERINE, FILACCE DI BANDIERINE, BANDIERINE CON ASTA

### TRIANGULAR FLAGS, BUNTING AND HANDHELD FLAGS

Completano la nostra gamma di prodotti bandierine di ogni formato e con diversi sistemi di confezione.

*A complete range of flags of all shapes and sizes with various types of packaging to choose from.*



### ACCESSORI PER BANDIERE DA PENNONE

### ACCESSORIES FOR FLAGPOLE FLAGS

Sacchetto di zavorra con moschettone, peso 190 g.

*Ballast bag with weight and carabiner, weight 190 g.*



Fascetta ad occhiello con anello metallico e moschettone.

*Strap with metal ring and carabiner.*

# PENNONE A VELA

FEATHER FLAG

Strutture componibili interamente in alluminio, robuste e durature nel tempo. Evitano le rotture tipiche dei terminali flessibili in vetro resina o filo armonico.

Facilità e velocità di montaggio grazie ai componenti rastremati ad innesto rapido. Bandiera in tessuto HDTEX con stampa passante a più colori.

**Struttura in alluminio garantita A VITA.**

**Con certificato di stabilità statica.**

**Disponibile anche in tessuto IGNIFUGO e RELIFE.**



*Robust long lasting modular structures made entirely from aluminium. Avoids the common breakages of flexible fiberglass or harmonic wire poles. Quick and easy assembly thanks to tapered snap couplings. HDTEX fabric with multi-coloured pass-through print.*

***Our aluminium structure is guaranteed for life.***

***Static stability certification.***

***Also available in both FIREPROOF and RELIFE fabrics.***

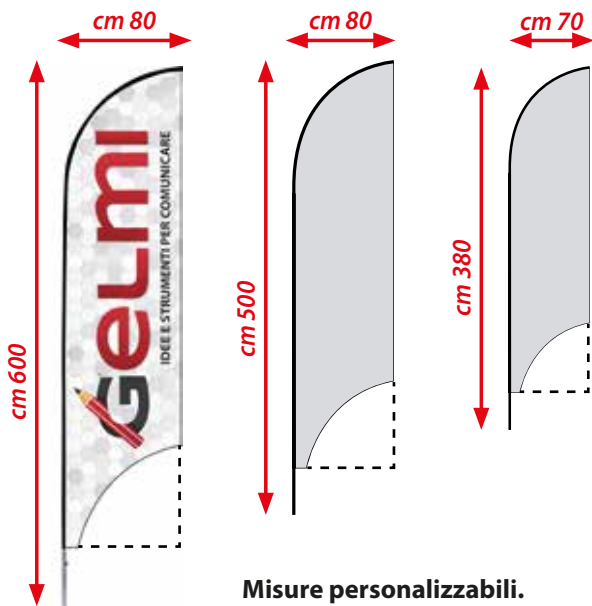

**Misure personalizzabili.**  
*Also available made to measure.*

**Innesto rapido con rastrematura**  
**Tapered snap couplings.**

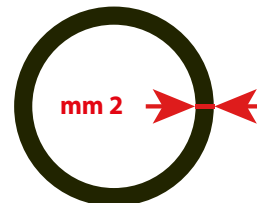

**Tubolari con spessore mm 2.**  
**2 mm tube thickness.**



**Disponibili nelle versioni DOUBLE PRINT**  
Stampa fronte e retro.

**Available in DOUBLE PRINT versions.**  
*Front and back print.*



**Possibilità di fascia elastica personalizzata.**

**Customizable elastic strip available.**

**Robusta borsa per il trasporto.**  
**Ingombro ridotto.**  
**Robust, compact carry bag.**



**Parte superiore in alluminio precurvato per evitare la rottura dell'asta e della bandiera.**

Perfetta vestibilità e tensione della bandiera.

***The curved aluminum top rod avoids any breaking of the pole and tearing of the flag.***  
*Perfect fit and fabric tension.*



**Disponibili anche in Versioni MAXI**

*Also available in MAXI versions*

**cm 117 x H 750**  
**cm 140 x H 930**





## **GOLD** Flagpole

Struttura componibile interamente in alluminio anodizzato disponibile nei colori oro, argento oppure nero, robusta e duratura nel tempo, facilità e velocità di montaggio grazie ai componenti rastremati ad innesto rapido. Bandiera in tessuto HDTEX con stampa passante a più colori.

**Disponibile anche in tessuto IGNIFUGO.**

*Robust long lasting modular anodized aluminium structures available in gold, silver and black.*

*Quick and easy assembly thanks to tapered snap couplings.*

*HDTEX fabric with multi-coloured pass-through print.*

***Also available in FIREPROOF fabric.***

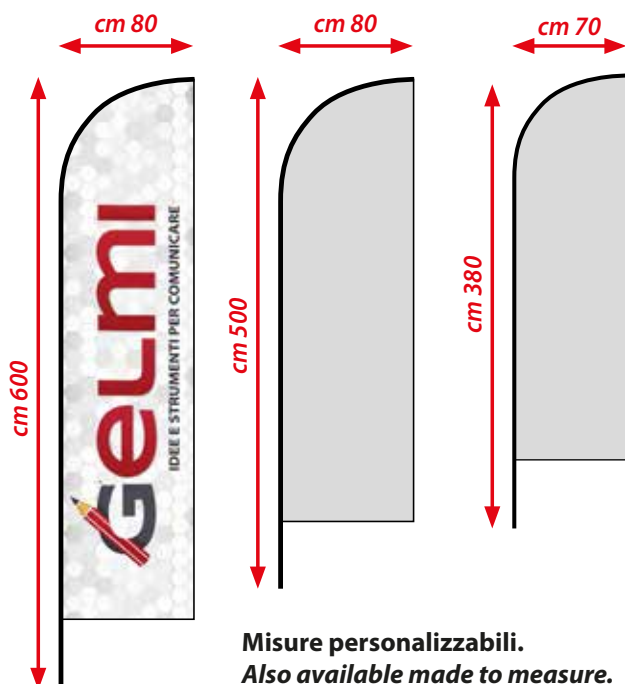

**Misure personalizzabili.**  
*Also available made to measure.*

Borsa in tinta con la struttura e personalizzata con la grafica della bandiera.  
*Carry bag in matching colours with customized flag graphics.*

### Gold



### Silver



### Black



**Disponibili nelle versioni DOUBLE PRINT**

Stampa fronte e retro.

**Available in DOUBLE PRINT versions.**

*Front and back print.*

Innesto delle sezioni con rastrematura.  
*Tapered snap couplings.*



**Possibilità di fascia elastica personalizzata.**

**Customizable elastic strip available.**

**Tubolari con spessore mm 2.**

*2 mm tube thickness.*

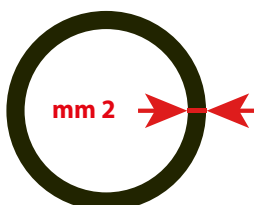

# PENNONE A GOCCIA

TEARDROP FLAG



Strutture componibili interamente in alluminio, robuste e durature nel tempo. Evitano le rotture tipiche dei terminali flessibili in vetro resina o filo armonico. Bandiera in tessuto HDTEX con stampa passante a più colori.

**Disponibile anche in tessuto IGNIFUGO.**

*Robust long lasting modular structures made entirely from aluminium.*

*Common breakages of flexible fiberglass or harmonic wire terminals are avoided.*

*HDTEX fabric with multi-coloured pass-through print.*

***Also available in FIREPROOF fabric.***

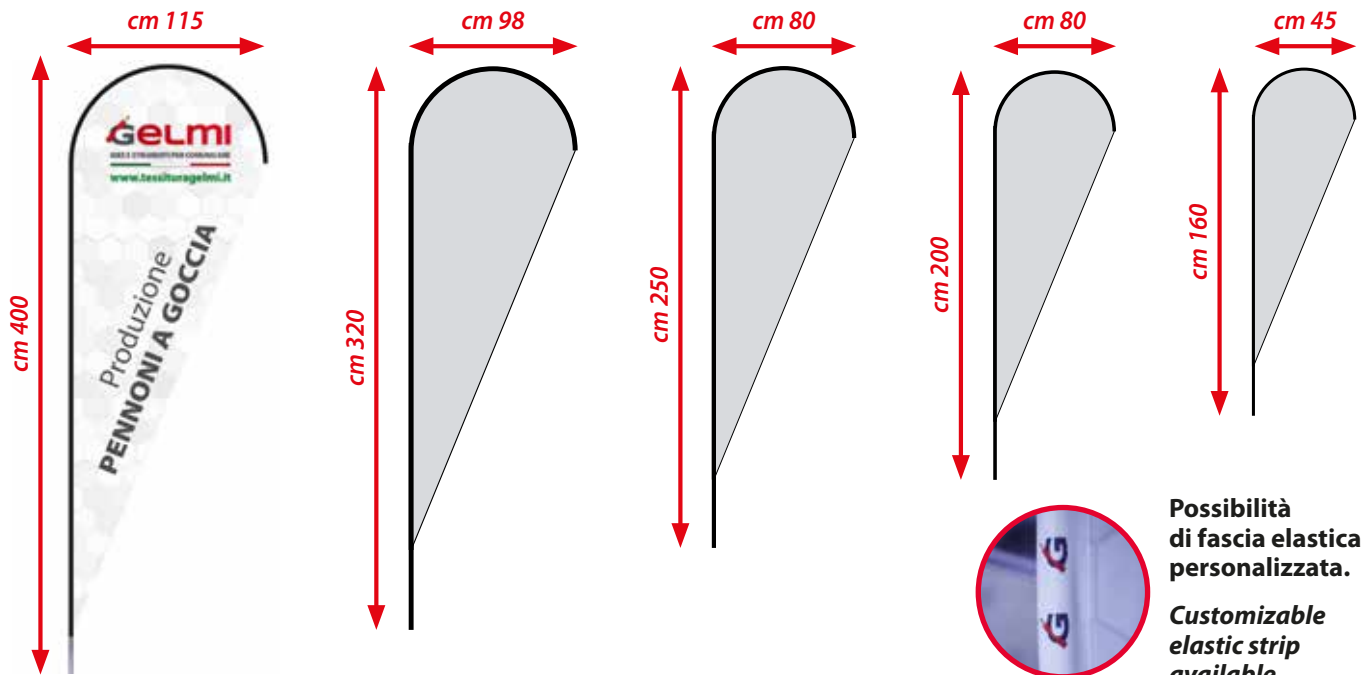

**Possibilità di fascia elastica personalizzata.**

**Customizable elastic strip available.**

**Disponibili nelle versioni DOUBLE PRINT nelle altezze cm 160-200-250-320**

**Available in DOUBLE PRINT versions in the following heights cm 160-200-250-320**

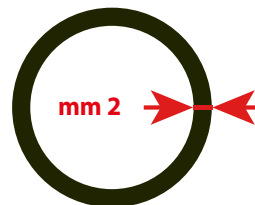

**Tubolari con spessore mm 2.**

**2 mm tube thickness.**

**Robusta borsa per il trasporto. Ingombro ridotto.**

**Robust, compact carry bag.**



**Parte superiore in alluminio precurvato per evitare la rottura dell'asta e della bandiera.**  
 Perfetta vestibilità e tensione della bandiera.

**The curved aluminum top rod avoids any breaking of the pole and tearing of the flag.**  
 Perfect fit and fabric tension.





# PENNONE RETTANGOLARE

RECTANGULAR FLAG



Strutture componibili interamente in alluminio, robuste e durature nel tempo.

Bandiera in tessuto HDTEX con stampa passante a più colori.

**Disponibile anche in tessuto IGNIFUGO.**

*Robust long lasting modular structures made entirely from aluminium.*

*HDTEX fabric with multi-coloured pass-through print. Also available in FIREPROOF fabric.*

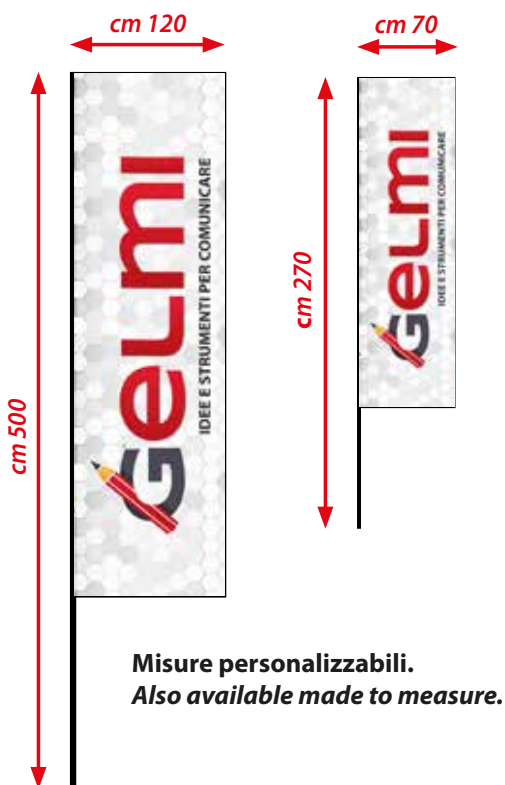

Misure personalizzabili.  
Also available made to measure.

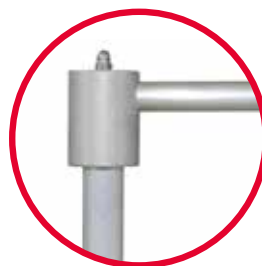

Con braccio superiore e perno girevoli.

With upper arm and pivot pin.

Tubolari con spessore mm 2.

2 mm tube thickness.

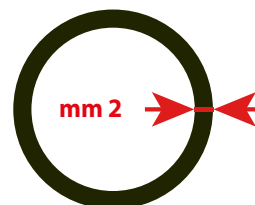

Robusta borsa per il trasporto.  
Ingombro ridotto.

Robust, compact carry bag.



Disponibili versione DOUBLE PRINT  
in altezza cm 270

Also available in DOUBLE PRINT versions  
in heights cm 270



**Versione alta cm 700**  
700 cm version

Braccio superiore girevole  
e pomolo in ottone.  
Upper arm swivel  
and brass knob.



Cerniera ribaltabile da  
interrare / per plinto.  
Folding hinge for plinth.



# EVENT FLAG

EVENT FLAG



Ideale per tutti gli eventi indoor e outdoor. La struttura componibile interamente in alluminio garantisce la massima resistenza e leggerezza **evitando le rotture tipiche delle strutture con terminali flessibili in vetroresina o filo armonico.**

**Disponibile anche in tessuto IGNIFUGO.**

*Perfect for all indoor and outdoor events. A modular aluminium structure offers maximum strength combined with low weight **avoiding the common breakages associated with flexible fiberglass or harmonic wire poles.***

***Also available in FIREPROOF fabric.***

## Modello rettangolare.

*Rectangular flag.*

## Modello a vela.

*Feather flag.*

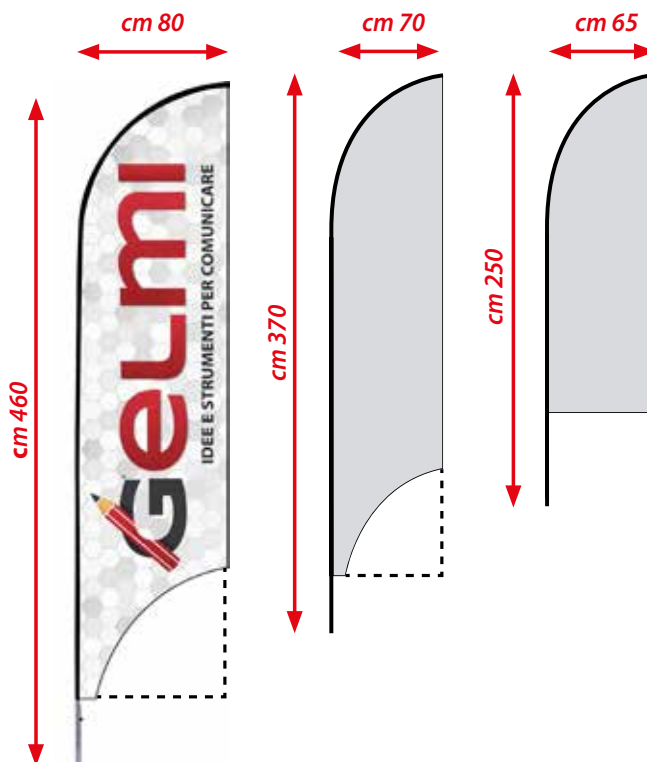
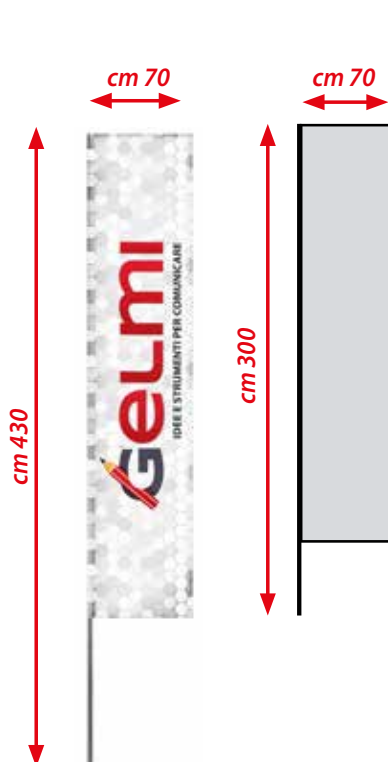

**Possibilità di fascia elastica personalizzata.**

*Customizable elastic strip available.*



**Struttura componibile interamente in alluminio.**

*Modular structure made entirely from aluminium.*



**Robusta borsa per il trasporto. Ingombro ridotto.**

*Robust, compact carry bag.*

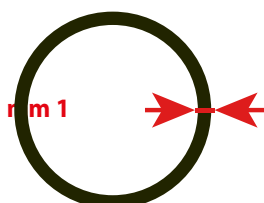

**Tubolari con spessore mm 1.**

*1 mm tube thickness.*



# BASAMENTI PER PENNONI

## FLAGPOLE BASES

### Zavorra multiuso per gazebo e bandiera

Diametro: cm 32

Peso: 15 Kg



### Multiuse ballast for tents & flags

Diameter: cm 32

Weight: 15 Kg

### Basamento in cemento rivestito plastica

Dimensioni: cm 40x40x10

Peso: 20 kg o 30 Kg



### Concrete plastic-coated base

Dimensions: cm 40x40x10

Weight: 20 kg or 30 Kg

### Basamento circolare in cemento

Maniglie e anello in gomma antigraffio

Diametro: cm 50, peso: 30 Kg

Diametro: cm 60, peso: 50 Kg



### Round concrete base

Scratch resistant rubber handles and ring

Diameter: cm 50, weight: 30 Kg

Diameter: cm 60, weight: 50 Kg

### Basamento pieghevole a croce in acciaio

Idoneo per l'interno

Dimensioni: cm 74+74

Peso: 2,5 Kg.



### Base with folding steel cross

Suitable for indoor use

Dimensions: cm 74+74

Weight: 2,5 Kg

### Ciambella riempibile con acqua o sabbia

(da posizionare sopra il basamento pieghevole a croce)



### Water or sand filled ballast

(For use with the folding cross base)

### Base pieghevole a croce con zavorra in sabbia e picchetti

Peso: 15 Kg



### Folding cross base with sand ballast and spikes

Weight: 15 Kg

### Basamento quadrato in acciaio

Dimensioni: cm 30x30

Peso: 3 Kg



### Steel square base

Dimensions: cm 30x30

Weight: 3 Kg

**Puntale in acciai.** Per fissare la struttura nella neve, nel terreno o nella sabbia  
Disponibile in due misure cm 40 e 53



### Steel toe cap. Secures the pole in

snow, in the ground or in sand

Available in two sizes, 40 and 53 cm

### Puntale a croce

Dimensioni base: cm 20+20 o cm 40+40

4 punti di ancoraggio per la massima stabilità nella neve, nella sabbia o nel terreno



### Cross tip

Base dimensions: cm 20+20 or cm 40+40

4 anchor points for maximum stability

in snow, sand or in the ground

### Trivella in plastica

Per fissare la struttura nella neve, nel terreno o nella sabbia



### Plastic drill

Secures the pole in snow, in the ground or in sand

### Basamento sottoruota



### Under-wheel base

### Basamento in plastica riempibile con acqua

Dimensioni: cm 48x48x13, Peso 20 Kg

Dimensioni: cm 52x52x20, Peso 37 kg



### Plastic base can be filled with water

Dimensions: cm 48x48x13, Weight 20 Kg

Dimensions: cm 52x52x20, Weight 37 Kg

## SNOW FLAG



Studiata per ottenere un effetto scenico d'impatto in ambienti esterni, anche con forte vento.

Bandiera in tessuto **HDTEX** con stampa passante.

Si fissa direttamente nella neve.

*Designed for maximum visual impact in outdoor environments, particularly in windy conditions.*

*Flag made from **HDTEX** fabric with pass-through printing.*

*Secured directly in the snow.*



## BANDIERINE ED ESPOSITORI DA TAVOLO/VETRINA

*FLAGS FOR TABLES AND DISPLAY UNITS*



Bandierina da tavolo con stampa bifacciale anche con grafiche differenti fronte/retro.

Disponibili in due dimensioni:

Struttura alta cm 38 con bandierina cm 13x30.

Struttura alta cm 28 con bandierina cm 10x20.

*Table flag with double sided printing allows different graphic designs on either side.*

*Available in two dimensions:*

*Structure height cm 38 with flag cm 13x30.*

*Structure height cm 28 with flag cm 10x20.*



Bandierina a vela da tavolo  
altezza cm 47.



*Table feather flag  
cm 47 height.*

Struttura a X da cm 25x40 fornita con telo monofacciale in tessuto 100% PES.



*X structure dimensions cm 25x40, provided with single-sided fabric.*

Struttura e telo imbustati singolarmente.

*Structure and fabric packed individually.*

# STAND UP da interno/esterno

STAND UP FOR indoor/outdoor use



L'unica struttura studiata per un montaggio facile ed immediato, senza uso di chiavi nè viti. Ideale per negozi, punti vendita, fiere, isole promozionali sia indoor che outdoor. Struttura componibile interamente in alluminio realizzata all'interno della nostra officina.

Confezione sartoriale curata nei minimi dettagli.

**Disponibile anche in tessuto IGNIFUGO.**

**A unique design for quick and easy assembly without the need for tools or screws.**

*Ideal for shops, fairs and promotional areas both indoor and outdoor.*

*Modular aluminium structure built in house.*

*Tailored finish with great attention to detail.*

**Also available in FIREPROOF fabric.**

**FACILE MONTAGGIO  
SENZA CHIAVI E VITI**



**EASY ASSEMBLY  
WITHOUT TOOLS OR SCREWS**

**Possibilità di fascia elastica personalizzata.**



**Customizable elastic strip available**



**MOD. V**



**MOD. R**



**MOD. G**



**MOD. PLUS**



**MOD. MAXI**

Il **MODELLO V** è disponibile anche con teli DOUBLEPRINT con stampa fronte/retro diversa.

**MODEL V** is also available with **DOUBLEPRINT** flag with different graphics on each side.

Fissaggio / Smontaggio rapido  
Tenuta a prova di movimenti

*Quick assembly / dis-assembly  
Designed for maximum stability*

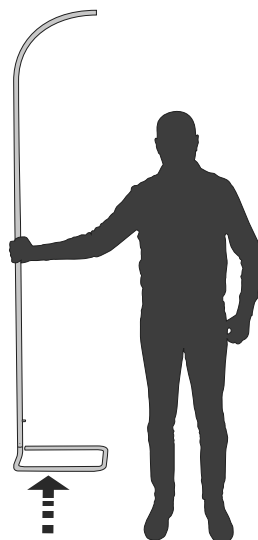

Per tutti i modelli disponibile  
basamento da esterno  
riempibile con acqua

*A plastic water filled  
outdoor base is available  
for all versions*





# BANDIERE VELA PIUMA

SMALL FEATHER FLAGS



## Bella, elegante e unica.

Ideale per negozi, punti vendita, fiere, isole promozionali e comunicazione indoor.

Prodotto inconfondibile grazie al basamento rivestito e alla fascia in lycra interamente personalizzati.

Asta componibile interamente in alluminio.

Eventuale allestimento con teli DoublePrint aventi doppia stampa fronte/retro.

**Disponibile anche in tessuto IGNIFUGO.**

## Beautiful, elegant and unique.

Ideal for shops, fairs, promotional booths and all kinds of indoor communication.

A unique product with a customizable lycra covered base.

Aluminium modular structure.

Available with DOUBLEPRINT flag with double-sided printing.

**Also available in FIREPROOF fabric.**



Possibilità di fascia elastica personalizzata.

Customizable elastic strip available.



Basamento rivestito.

Customizeable lycra covered base plate



Disponibile anche in versione DOUBLEPRINT!

DOUBLE SIDED printing available!

# CREA LA TUA BANDIERA

CREATE YOUR FLAG

Possiamo creare la bandiera più adatta alle tue esigenze, disegna la tua forma e noi la realizziamo!

*We can produce any flag you desire; just draw it and we'll make it!*

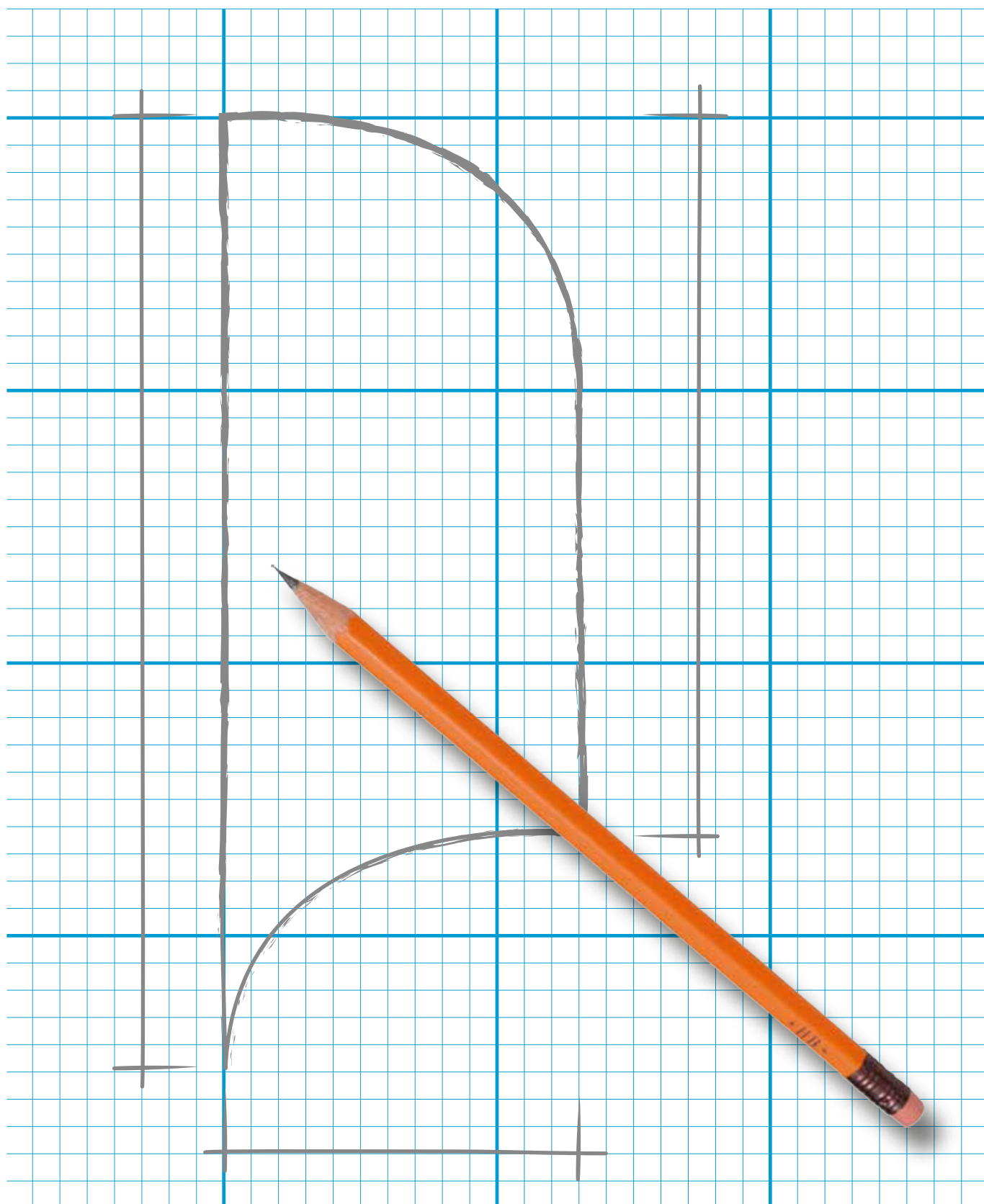

# STAMPA GRANDE FORMATO E GRANDI EVENTI

LARGE FORMAT & MAJOR EVENTS PRINTING



## Realizzazione di maxi teli pubblicitari senza limiti dimensionali.

A disposizione tessuti ignifughi per utilizzo indoor e tessuti traforati passavento per uso outdoor.

Possiamo realizzare:

- maxiteli pubblicitari
- allestimenti di grandi dimensioni
- rivestimenti murali
- teli per nostre strutture in alluminio
- teli stadio

e molto altro ancora...

Soluzione ottimale per valorizzare gli ambienti o per nascondere momentaneamente lavori di riqualificazione.

## Production of unlimited maxi sized advertising banners.

Also available in fireproof fabrics for indoor use and perforated mesh fabrics for outdoor use.

We can produce:

- Maxi and outsized advertising banners
- large format coverings
- wall coverings
- fabrics for our aluminium structures
- stadium drapes

and much more...

The perfect solution to decorate your settings or to discretely hide renovations.





## REALIZZAZIONI

### Personalizzazione stand preallestiti

Teli stampati in tessuto ignifugo classe 1 per decorazione stand. Facile e veloce nell'allestimento grazie al velcro. Teli riutilizzabili più volte.

Ingombro e peso ridotti, un telo da cm 300x180 pesa 1,20 kg e piegato ingombra cm 80x50x10.



## PROJECTS

### Customization of standard booths

Decoration and customization of display booths with Class 1 fireproof fabrics. Quick and easy assembly using velcro straps. Reusable fabrics for multiple events. Reduced overall dimensions and weight, a 300x180 cm fabric weighs only 1,20 KG and when folded takes up just 80x50x10 cm.

### Mostre fotografiche - Photographic exhibitions

Allestimento di mostre fotografiche con strutture autoportanti o con kit di appenditura a muro, realizzati ad hoc in base alle esigenze del cliente. Ideali sia per mostre permanenti che per mostre itineranti.

Preparation of photographic exhibitions with self-standing structures or with wall-kit fixing, made according to customer needs. Ideal for both permanent exhibitions and for traveling exhibitions.



### Teli per centrocampo

### Midfield advertising banner



### Maxi teli per eventi

### Maxi-banner for events





# ALLESTIMENTO EVENTI

EVENTS SET-UP



## AFFIDATI A NOI PER I TUOI EVENTI.

Allestimento eventi indoor e outdoor con possibilità di servizio di montaggio/smontaggio e noleggio delle strutture.

## TRUST US FOR YOUR EVENTS.

Indoor and outdoor events set up with the possibility of assembly / disassembly service and rental of the structures.

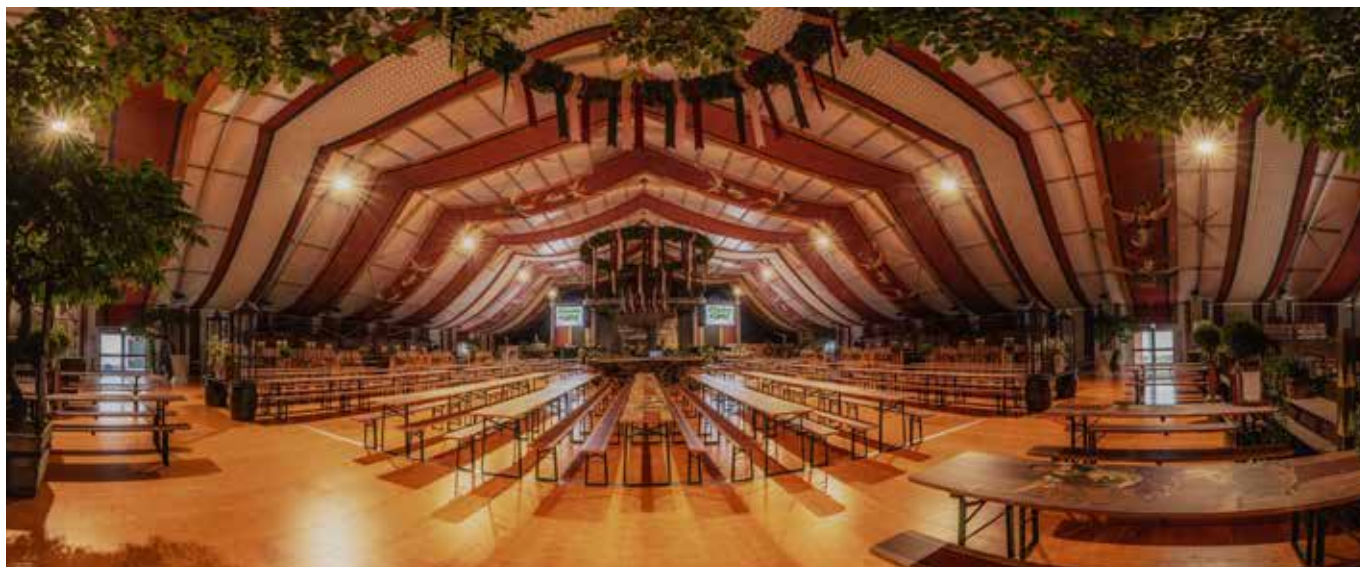





ALLESTIMENTO EVENTI EVENTS SET-UP



# NASTRI IN TNT: segnapercorso e copripallet

TNT TAPES: route markers & pallet covers



**Per delimitare in sicurezza.**

Fasce in tnt ad alta resistenza allo strappo, con grafiche completamente personalizzabili. Stampa ad alta definizione, senza limiti di colore o sfumature.

Utilizzabili anche come copertura pallet, nastri segna percorso e allestimenti indoor/outdoor.

**Possibilità di tessuto ignifugo GOLD BANNER FIRE RESISTANT.**

**Enclose a selected area in safety .**

High tear resistance TNT Tape with fully customizable graphics.

High definition printing, unlimited colours and designs.

Can also be used to cover pallets or as a route marker for indoor and outdoor events.

**Also available in GOLD BANNER FIRE RESISTANT fireproof fabric.**



**Altezze personalizzabili.**

*Customizable heights.*

**Copripallet disponibili anche nella versione a cappuccio.**

---

*Also available as a top cap cover for pallets.*



# PETTORINE

SPORTS BIBS



**Realizzate completamente in Italia con tessuti di alta qualità stampati in digitale.**

Completamente personalizzabili fronte/retro senza limitazioni di colori e sfumature, con numerazione progressiva. Abbiamo a disposizione differenti tipologie di pettorine per ogni esigenza del cliente.

**Digitally printed bibs made in Italy with high quality fabrics.**

Consecutively numbered, fully customizable front / back graphics, no limits for desired colours or graphic designs.

A wide selection of bib designs to choose from for your event.

## CANOTTA IN LYCRA LYCRA SPORT BIBS



## POSSIBILITÀ DI PETTORINE CON OMOLOGAZIONE F.I.S.

**BIBS WITH F.I.S.  
HOMOLOGATION AVAILABLE**

CANOTTE DISPONIBILI ANCHE IN TESSUTO MICROSENSE. Studiato per ottimizzare la performance degli atleti, in particolare per lo sci di fondo, grazie alla perfetta traspirabilità delle fibre.

SPORT BIBS AVAILABLE IN MICROSENSE FABRIC. Specially designed for optimal athletic performance, in particular for cross country skiing, thanks to the use of breathable fabrics.



## PETTORALE IN TNT TNT SPORT BIBS



Pettorali con cucitura di elastici/laccetti o laccetti fustellati. Sport bibs with sewn or die cut straps.

Disponibili anche con TNT ecocompatibile. Also available in environmentally friendly tnt.



## NUMERI GARA RACE NUMBERS



## PETTORALE DA SNOWBOARD SNOWBOARD BIBS



## PETTORALE CON ELASTICI SPORT BIBS WITH ELASTIC STRAPS



# CORNICE IN ALLUMINIO

ALLUMINIUM FRAME



## L'ARTE DI COMUNICARE

**Arreda e diffonde  
il Vostro marchio con eleganza.**

Struttura di facile montaggio  
con teli intercambiabili.

**POSSIBILITÀ DI PANNELLO FONOASSORBENTE**



## THE ART OF COMMUNICATION

**The perfect blend of style and elegance,  
when communication becomes  
decoration.**

Easy to install with interchangeable fabrics.

**SOUND-ABSORBING PANEL AVAILABLE**

Kit già pronto per l'allestimento  
composto da:  
Telo personalizzato  
Struttura componibile  
4 angolari in alluminio  
Accessori per il montaggio



The supplied kit is ready to use  
and comes complete with:  
Personalized fabric  
Modular frame  
4 aluminium angular joints  
Mounting accessories

MONTAGGIO IMMEDIATO E VELOCE  
DELLA GRAFICA  
GRAZIE AL BORDO SPESSORATO  
CUCITO SUL TESSUTO

QUICK AND EASY INSTALLATION  
OF THE INTERCHANGEABLE GRAPHICS  
HELD SECURELY IN PLACE BY AN  
INTEGRATED SILICONE STRIP





# TEXTILE FRAME



**Grande impatto scenografico:** la struttura semplice e lineare lascia completo spazio ed importanza all'immagine. Leggero, di facile trasporto e montaggio.

Completo di borsa per il trasporto e kit per il montaggio.

POSSIBILITÀ DI VERSIONE BIFACCIALE CON GRAFICHE DIFFERENTI FRONTE/RETRO.

Disponibile anche con tessuto  .

**Great visual impact:** the simple linear structure lets the desired image stand out in all its glory.

Lightweight and easy to transport and assemble.

A transportation bag and assembly kit are included.

ALSO AVAILABLE WITH DOUBLE SIDED PRINTING.

Also available with  fabric.

Realizzato con nostri profili in alluminio da mm 40x40 ad altissima resistenza.

*Made with our 40x40 mm aluminium sections.*



Telo con bordo spessorato studiato per un immediato inserimento nel profilo e facilmente intercambiabile.

*A silicone strip slots quickly and easily into the specially designed channel in the frame.*



Base ad arco per interni, in ferro verniciato e protezioni in gomma.

*Arched painted iron base with rubber protection pads for indoor use.*



Base da 10 kg per esterni, in ferro verniciato.

*10 kg base in painted iron for outdoor use*



**DIMENSIONI STANDARD**  
STANDARD DIMENSIONS

*cm 80 x h 200 cm 145 x h 200 cm 180 x h 180 cm 250 x h 180 cm 300 x h 250*

POSSIBILITÀ DI DIMENSIONI PERSONALIZZATE! ALSO AVAILABLE MADE TO MEASURE!

DISPONIBILE ANCHE CON TESSUTO TRAFORATO PASSAVENTO ALSO AVAILABLE WITH PERFORATED FABRIC FOR USE IN WINDY CONDITIONS

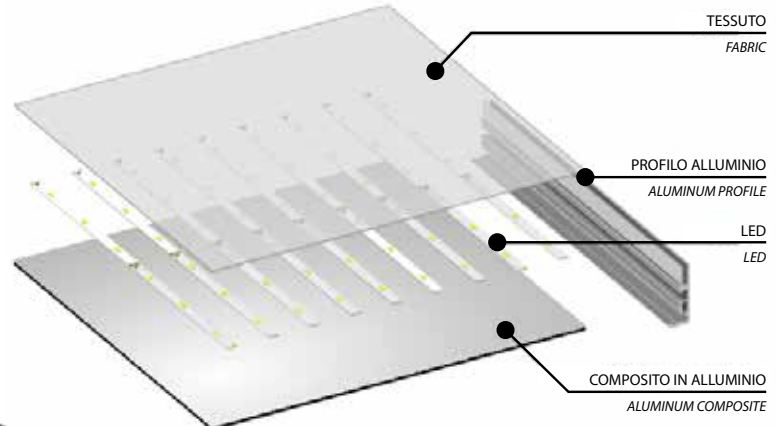

Pannello LED retroilluminato senza limiti dimensionali.  
**Luminosità costante e uniforme su tutta la superficie anche nelle misure più grandi.**  
Cornice con profilo in alluminio a garanzia di massima resistenza.  
Leggero e facilmente trasportabile grazie al peso ridotto, solo 6 Kg/m<sup>2</sup>.  
Immagini facilmente intercambiabili.

*Made to measure backlit LED panel.*  
**Delivers a constant and uniform illumination over the entire surface even in large sizes.**  
*The aluminium frame profile guarantees maximum strength and durability.*  
*Lightweight and easy to transport, just 6 Kg/sqm.*  
*Easily interchangeable graphical designs.*







GRANDE IMPATTO VISIVO con i Led ad alta luminosità.  
OTTIMO RAPPORTO QUALITÀ/PREZZO.

GREAT VISUAL IMPACT with high performance LEDs.  
EXCELLENT VALUE FOR MONEY.



**Strutture  
MODULABILI**

**MODULAR  
Structures**

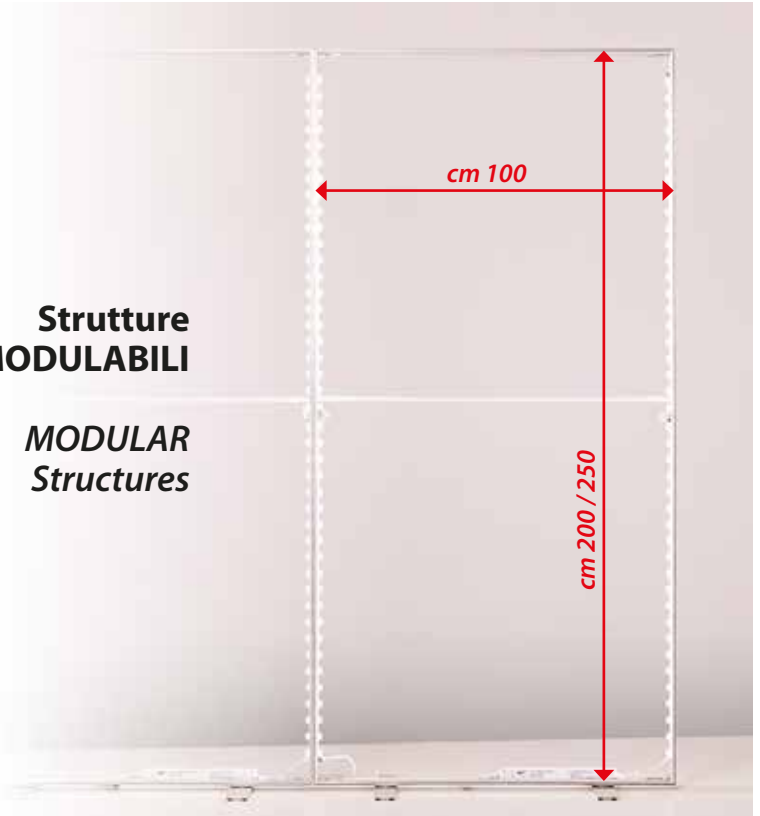

Struttura realizzata con profili in alluminio e led  
Montaggio in pochi minuti e senza chiavi

*Supporting structure made from aluminium  
sections with integrated LEDs  
Assemble in seconds without tools*



Facile e veloce cambio di telo  
*Quickly and easily change the personalized fabric*



Scatola di cartone per il trasporto con gomma  
antiurto e istruzioni per il montaggio

*Cardboard transportation box with shockproof  
rubber protection and assembly instructions*



# ESPOSITORI ROLLUP

## ROLLUP DISPLAYS



**Strutture avvolgibili in alluminio** che consentono un'estrema facilità e velocità di utilizzo:

Il telo è già montato all'interno della struttura.

Realizzato in tessuto 100% poliestere con stampa in alta risoluzione, studiato nel peso e nella costruzione per consentire una tensionatura perfetta in ogni punto, garantita nel tempo senza il fastidioso effetto "curling" tipico dei teli in PVC che si arricciano ai bordi.

Corredate da pratica borsa per il trasporto.

A disposizione varie tipologie di strutture e dimensioni.

Disponibile anche con tessuto .

### Aluminium structure

with pre wound fabric for quick and easy set up:

The fabric is pre installed inside the base.

Complete with 100% polyester high-resolution printed fabric, specifically designed to provide perfect tension across the entire length.

Guaranteed to avoid the annoying "curling" effect commonly found on the edges of PVC displays.

Supplied with a practical carry bag.

Available in various designs and sizes.

Also available with fabric.

## ROLLUP BASIC monofacciale

### BASIC ROLLUP single sided print



Anche il modello basic è studiato nei minimi dettagli. Il profilo superiore, progettato per l'inserimento del telo con keder, permette una **sicura tenuta del tessuto anche all'esterno.**



Basic in name but produced with great attention to detail. Sturdy piping on the top section **gives a solid hold of the fabric even when used outdoors.**

Disponibilità di zavorre e picchetti per l'utilizzo all'esterno.

Ballast and spikes available for outdoor use.



# ROLLUP DELUXE

versione bifacciale  
two-sided version

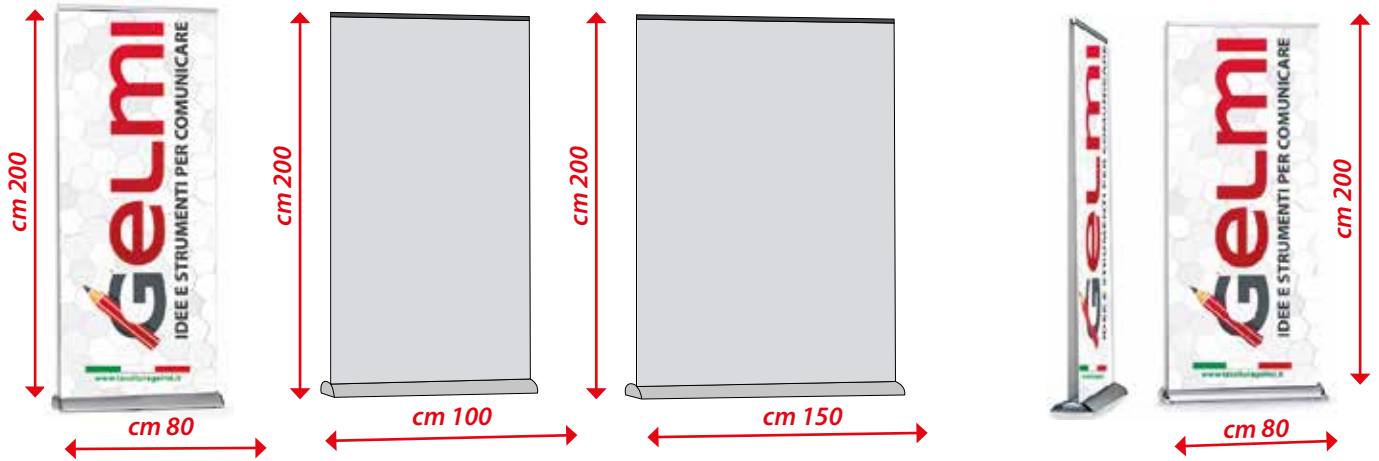

VERSIONE ELEGANTE E DI ALTO DESIGN

ELEGANT AND CLASSY DESIGN

Basamento con laterali cromati e viti inferiori di livellamento.

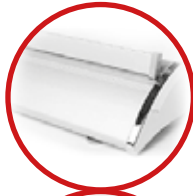

Elegant base with chromed sides and leveling screws.

Asta telescopica per regolare l'altezza della struttura e la tensionatura del telo.



Telescopic rod to easily adjust the height and tension of the fabric.

Comoda e pratica borsa imbottita per il trasporto.



Practical and comfortable padded carrying bag.

# ROLLUP PLUS

**6 m<sup>2</sup> di visibilità!**

Doppia asta telescopica graduata per regolare l'altezza della struttura e avere la perfetta tensionatura del telo.

**6 m<sup>2</sup> of visibility!**

Double graduated telescopic rod allows easy height adjustment to achieve the perfect tensioning of the fabric.





# CARTOTEX



L'evoluzione del cartone...

Un nuovo mondo della comunicazione.

**ECOLOGICO, ECONOMICO, ELEGANTE e COMODO!**

cartone + tessuto = **CartoTEX**

The evolution of cardboard...

A new dimension of communication.

**ECOLOGICAL, ECONOMICAL, ELEGANT and PRACTICAL!**

cardboard + textile = **CartoTEX**

Kit di tre cartoni + 1 telo stampato.

Three cardboard boxes + 1 printed fabric.

Aprire/montare  
i tre cartoni.

Open and assemble  
the boxes.



Innestarli.

Join the boxes.



La struttura autoportante è  
pronta da vestire con il telo.

The self-supporting structure  
is now ready to be covered with the fabric.

cm 22      cm 50



cm 160 / 176



## X BANNER



Particolare per fissaggio al terreno.  
Particular for anchoring eyelets.:



Struttura monofacciale di facile montaggio e con telo intercambiabile, indispensabile per una pubblicità completa ed efficace nei punti vendita, congressi, fiere...

### Imbattibile rapporto qualità prezzo.

Perfetta tensionatura del telo e buona stabilità a terra. Completo di borsa per il trasporto.

Disponibile anche con tessuto  .

*Quick and easy to assemble, single sided structure with interchangeable fabric, ideal for instant and effective advertising in stores, congresses, trade fairs ...*

### Unbeatable value for money.

*Perfect tensioning of the fabric and floor stability. Carry bag included.*

Also available with  fabric.

## TOTEM BIFACCIALE DOUBLE SIDED TOTEM

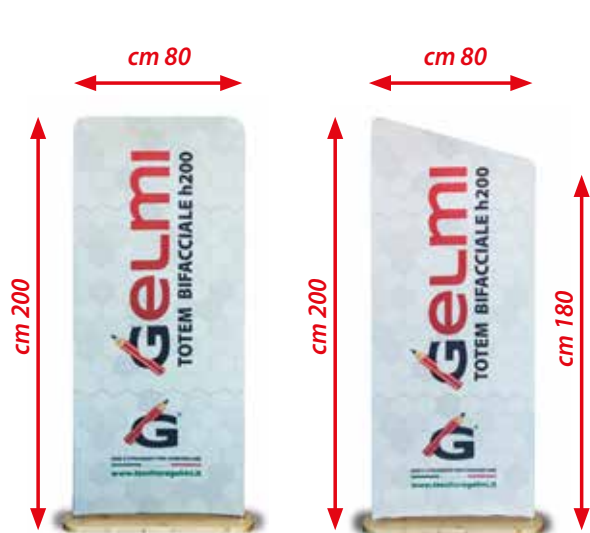

Basamento rivestito

Covered base

### Calza a pennello la tua grafica.

Struttura bifacciale in alluminio realizzata interamente nelle nostre officine, totalmente rivestita con telo in tessuto lycra per una perfetta vestibilità. Possibilità di basamento personalizzato.

### A perfect fit for your graphics.

*In house designed and built aluminium frame with double-faced Lycra cover for a perfect fit. Customized base available.*

# Linea <sup>INFINITO</sup> ∞

INFINITY LINE



La LINEAINFINITO permette di avere **elementi base che possono essere composti, smontati e re-inventati** in modi diversi per creare una INFINITÀ di soluzioni. Le strutture sono realizzate con eleganti profili in alluminio ossidato color argento.

- Interamente prodotte in Italia.
- Componibili secondo necessità.
- Modulabili.
- Riutilizzabili in più soluzioni.
- Personalizzabili nelle dimensioni.
- Integrabili in qualsiasi momento.
- Leggere e di semplice montaggio.
- Con pratiche borse per il trasporto.

Disponibile anche con tessuto  .

The INFINITY LINE is made up of **base elements that can be combined, removed and re-positioned** in many different ways to create an INFINITE number of solutions. The elegant supporting structures are made from silver anodized aluminium.

- Manufactured entirely in Italy.
- Adaptable to individual requirements.
- Modular.
- Reusable in numerous situations.
- Customizable in size.
- Expandable when necessary.
- Lightweight and easy to assemble.
- Practical carrying bags for transport.

Also available with  fabric.

**MONTAGGIO FACILE E VELOCE: OCCORRE SOLAMENTE UNA CHIAVETTA ESAGONALE!**  
**QUICK AND EASY TO ASSEMBLE WITH JUST A TORX KEY!**

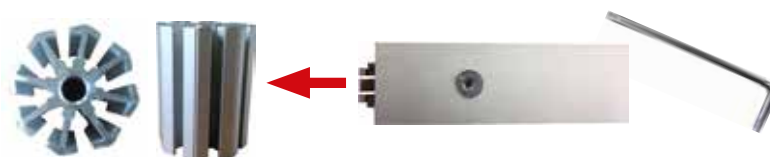

Da questa struttura, senza costi aggiuntivi, potete ottenere infinite combinazioni.

From this simple design, without any further cost, you can obtain any number of combinations.

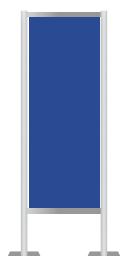



**TOTEM ELLITTICO**  
ELLIPTICAL TOTEM

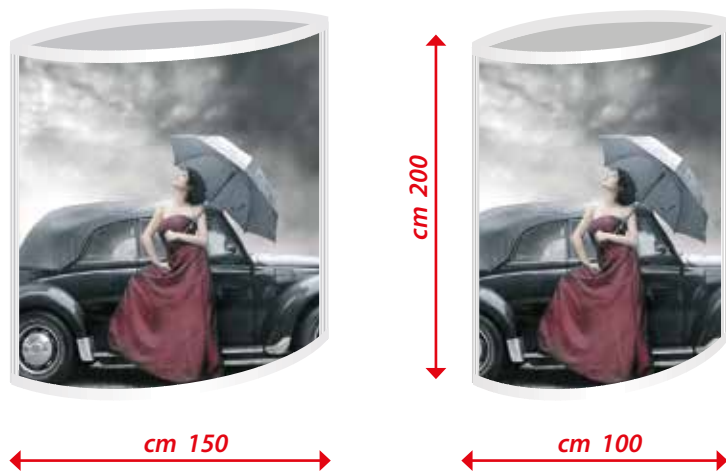

**PORTA BANNER TORRE**  
TOWER BANNER DISPLAY

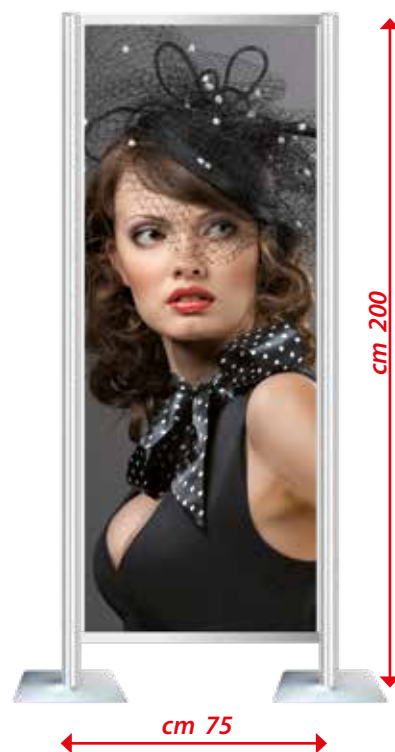

**TRANSENNA**  
CROWD BARRIER

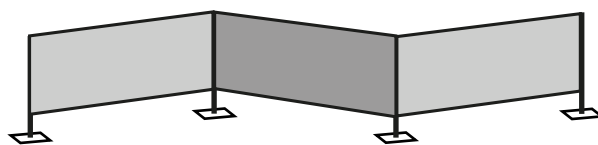

**CAVALLETTO**  
PAVEMENT SIGN



Particolare aggancio.

Fixing detail.

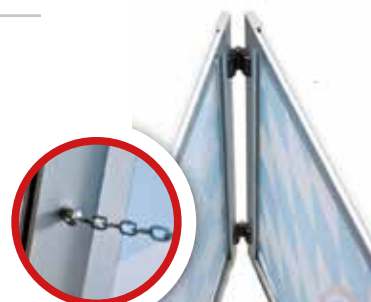

# FONDALI PROGETTO INFINITO

INFINITY BACKDROP LINE



Disponibili nelle misure standard.  
Realizzabili in qualsiasi dimensione richiesta grazie alla nostra officina meccanica interna.

Available in standard sizes.  
Also available made to measure thanks to our in house workshop.

## MISURE STANDARD STANDARD SIZES

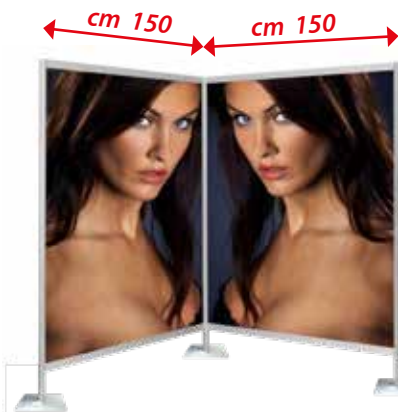

## STRUTTURE REALIZZATE ADHOC PER IL CLIENTE MADE TO MEASURE DESIGNS



IDEALE ANCHE PER RETROPREMIAZIONI.  
PERFECT FOR AWARDS BACKDROP

ABBINABILE AI NOSTRI BANCHETTI IN ALLUMINIO  
PER LA CREAZIONE DI ISOLE PROMOZIONALI.  
WHEN COMBINED WITH OUR ALUMINIUM DESK TO CREATE  
A PROMOTIONAL BOOTH



# FONDALI ZIP

## ZIP BACKDROP



Serie di fondali con struttura componibile in alluminio e telo completamente personalizzato che avvolge tutta la struttura.

*A series of modular aluminium backdrops entirely covered with fully customized fabrics.*

**Chiusura inferiore tramite cerniera**  
Zip per maggiore aderenza alla struttura senza pieghe o grinze.



*Zip closure at the base for greater adherence to the structure without any creases or wrinkles.*

**Assemblaggio semplice ed intuitivo grazie ai riferimenti numerici degli inserti.**



*Simple and intuitive assembly thanks to the numbered references on the inserts.*

**Pratica e robusta borsa trolley per il trasporto.**



*Practical and sturdy trolley for transportation.*

**Compresi nel kit: guanti e telo a protezione della stampa.**

*Comes with gloves and a cloth to protect the print.*

**versione OASI**

*OASIS version*

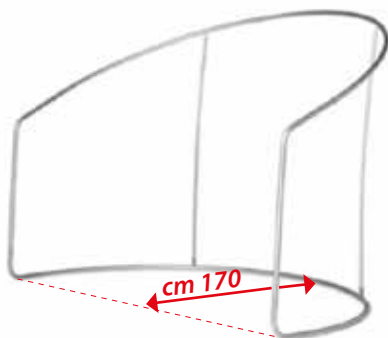
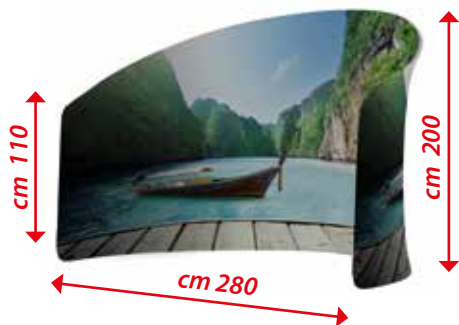

**versione CURVA**

*CURVED version*

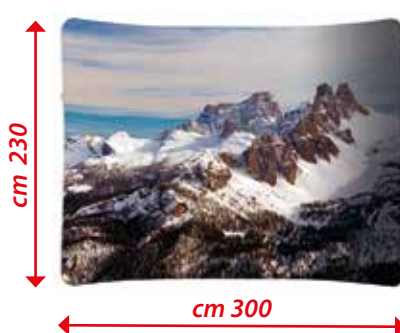

**versione DIRITTA**

*STRAIGHT version*



**con basi**  
*with bases*



## FONDALE POPUP POPUP BACKDROP



Clip ad innesto rapido.  
Quick connection clip.



Pratica e robusta borsa trolley per il trasporto.  
Practical and sturdy trolley for transportation.

Struttura in alluminio che **consente una veloce e immediata apertura/chiusura ad ombrello robusta e utilizzabile per molte volte**, completa di telo in tessuto stampato ad alta risoluzione applicato alla struttura tramite velcro. Grafica facilmente intercambiabile. Disponibile nelle misure cm 224x224 e cm 297x224.

*Strong and durable aluminium structure for **quick and easy setup/removal**. Comes complete with high resolution printed fabric cover held securely in place with velcro. Easily interchangeable graphics. Available in sizes cm 224x224 and cm 297x224.*

Disponibile anche con tessuto .

Also available with fabric.

## ESPOSITORE DA SOFFITTO CEILING DISPLAY

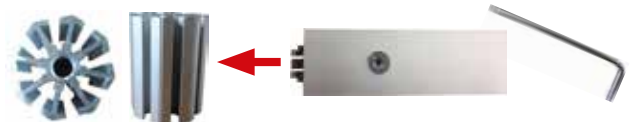
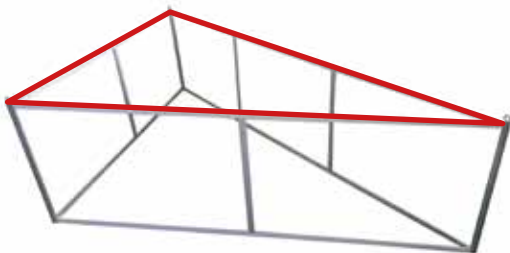

TUTTE LE FORME CHE VUOI

ANY SHAPE YOU WANT

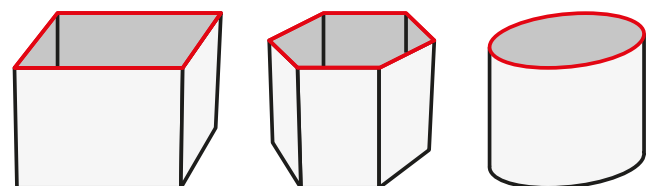

Struttura componibile in alluminio realizzata **all'interno della nostra officina**, dimensioni e forma in base alle esigenze del cliente. Con kit per il montaggio. Tessuto stampato in digitale confezionato ad hoc per una perfetta vestibilità della struttura.

*Made to measure aluminium modular structures **designed and built in our in house workshop**. Mounting kit included. Digitally printed and tailored fabric cut specifically for a perfect fit for each and every design.*

# EPsystem



## COPERTURA E CUSCINI PER PALLET EPAL COVERS AND CUSHIONS FOR EPAL PALLETS

Un'idea simpatica, veloce ed economica  
per VESTIRE i tuoi eventi.

A brilliantly simple, fast and inexpensive  
way to DRESS UP yours events.

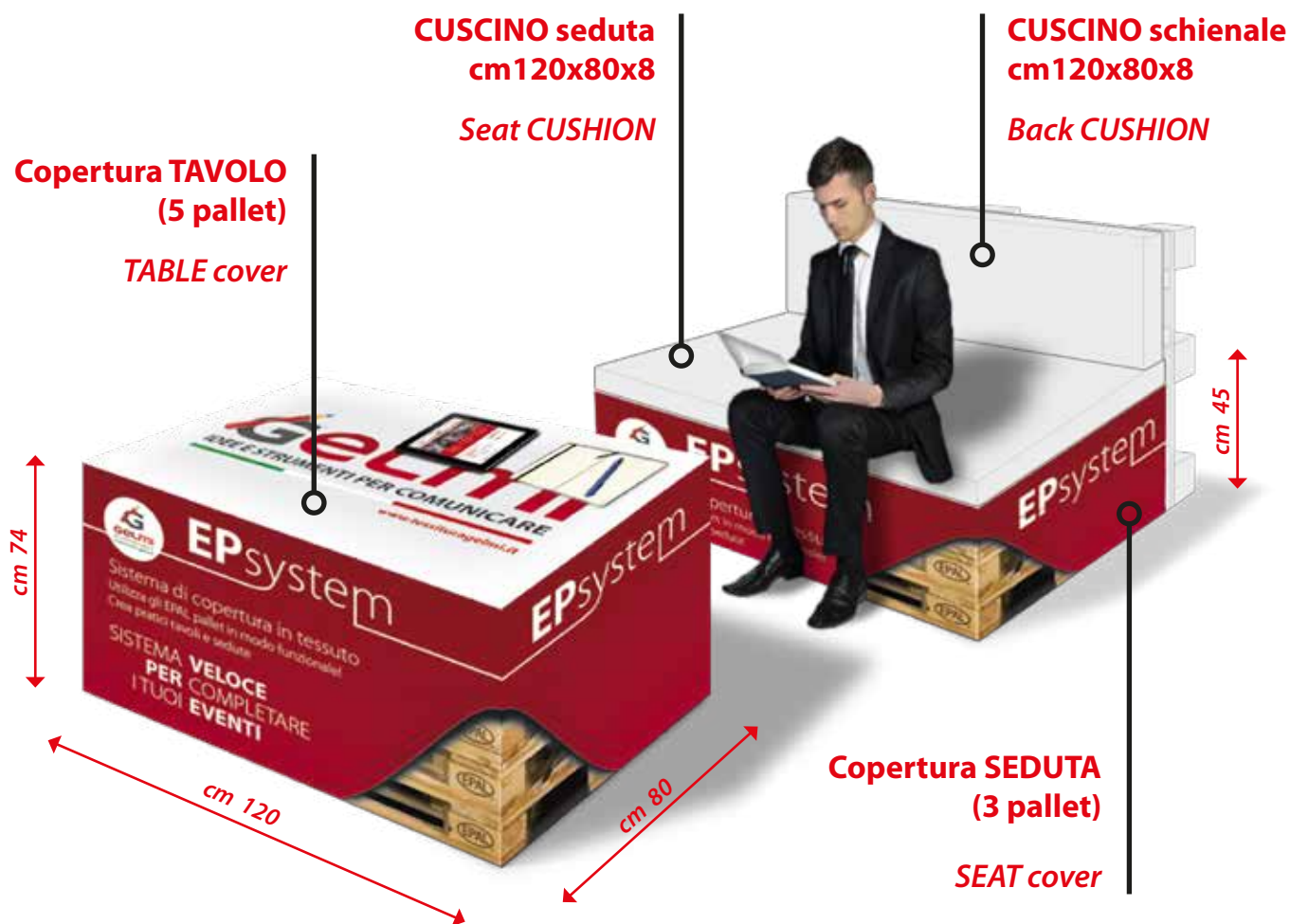

PERSONALIZZABILE  
RESISTENTE  
COMPONIBILE

CUSTOMIZABLE  
DURABLE  
MODULAR



## BEAN BANNER



**Struttura bifacciale in vetroresina realizzata in Italia,** rivestita in tessuto studiato per il perfetto tensionamento. La struttura si monta da sola una volta tolta dalla pratica sacca per il trasporto. Ideale per eventi all'aperto. In dotazione picchetti per ancoraggio.

**Double sided fiberglass design made in Italy.**  
The fabric is tailored for perfect tension.  
Automatically opens upon removal from its practical carry bag. Ideal for outdoor events.  
Comes complete with pegs.

## SNOW BANNER



Striscione in tessuto traforato passavento. Completo di pali da fissare nella neve e borsa per il trasporto. **Grande facilità nel montaggio e nel trasporto.**

**Polymesh fabric banner.**  
Fixing poles and carry bag included.  
**Quick and easy to set up and transport.**

## TELI PER PORTE DA SCI

SLALOM GATES



Teli per porte da sci in tessuto traforato passavento  
Stampa in passante digitale sublimatico da carta transfer ad alta definizione con colori brillanti.  
Dimensione cm 80x50.  
Con asola a destra e a sinistra con elastico sulla parte superiore.

*Slalom gates in perforated fabric. Digital sublimation printing from high-definition transfer paper with bright colours.*  
Size 80x50 cm.  
*Includes right and left pole hems and elastic top.*



# GOLF BANNER



Struttura tubolare in alluminio, di facile montaggio senza chiavi o viti. Allestito con **telo bifacciale a cappuccio, in lycra studiato per una perfetta vestibilità della struttura.** Per tutti gli eventi outdoor.

*Aluminium tubular structure, easy to assemble without tools or screws. Complete with **double side Lycra fabric cover designed for a perfect fit.** For all kinds of outdoor events.*

**FACILE MONTAGGIO  
SENZA CHIAVI E VITI**



**EASY ASSEMBLY  
WITHOUT TOOLS OR SCREWS**

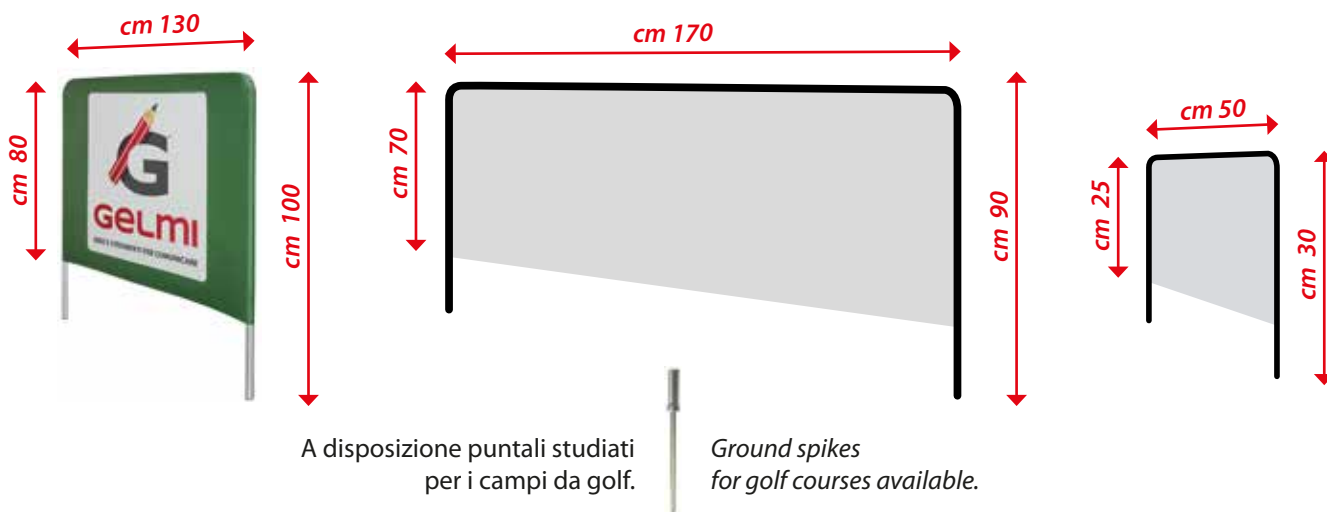

# TRANSENNA BIFACCIALE DOUBLE FACED BARRIER



**FACILE MONTAGGIO  
SENZA CHIAVI E VITI**



**EASY ASSEMBLY  
WITHOUT TOOLS OR SCREWS**

**Struttura tubolare in alluminio, di facile montaggio.** Telo bifacciale a cappuccio, studiato per una perfetta vestibilità della struttura. Completa di basamenti e picchetti per il fissaggio al terreno.

*Easy to assemble aluminium tubular structure. Complete with double sided fabric cover designed for a perfect fit. Bases and ground spikes included.*

Disponibile anche con tessuto  .

Also available with  fabric.



## GAZEBO PROFESSIONALE IN ALLUMINIO CON CERTIFICATO DI STABILITÀ.

**PROFILO ESAGONALE CON SPESSORE 2 mm.**  
**Garanzia di robustezza per un gazebo professionale che duri nel tempo.**

Realizziamo gazebo professionali in alluminio adatti per eventi indoor e outdoor, anche in condizioni estreme grazie alla struttura esagonale. Possono essere completamente personalizzati a più colori e immagini su tessuto impermeabile e ignifugo da noi appositamente studiato per la massima resa. Le dimensioni disponibili sono mt. 3x3, mt. 4,5x3 e mt. 6x3. Ogni struttura è fornita con pratica borsa trolley per il trasporto, corde e picchetti.

## PROFESSIONAL ALUMINIUM GAZEBO TENT WITH STABILITY CERTIFICATION.

**2 mm THICK HEXAGONAL PROFILE.**  
**A guarantee of strength for a long lasting professional gazebo tent.**

We produce professional aluminium gazebo tents perfect for both indoor and outdoor events, even in extreme conditions thanks to the use of hexagonal structures. Fully customizable with multiple colors and designs in our specifically developed waterproof and fireproof fabrics for optimal results. Available sizes: mt. 3x3, mt. 4,5x3 and mt. 6x3. Each structure come with a practical trolley for transport, guide ropes and pegs.

### DETTAGLI STRUTTURA STRUCTURE DETAILS

SEZIONE TUBOLARE  
TUBULAR SECTION

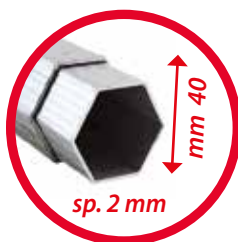

GIUNTO CON ANELLO  
JOINT WITH PULL RING



BASE APPOGGIO  
BASE

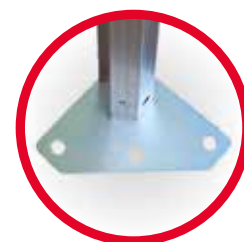

### PERSONALIZZAZIONI DISPONIBILI DEL TETTO AVAILABLE ROOF CUSTOMIZATION

art.  
**Basic**



Tetto neutro bianco  
oppure nero.  
White or black roof.

art.  
**Basic Plus**



Tetto neutro bianco o nero  
e personalizzazione ai lati.  
White or black roof  
with customization of the sides.

art.  
**Full Print**



Interamente personalizzato  
senza limiti di colore o immagini.  
Tessuto Ignifugo classe 1.  
Full print roof without any limitations  
of colours or graphics. Fireproof fabric.

### DIVERSE COLORAZIONI DISPONIBILI PER L'INTERNO DEL TETTO FULL PRINT FULL PRINT ROOF WITHOUT ANY LIMITATIONS OF COLOURS OR GRAPHICS

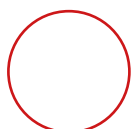

WHITE (standard)

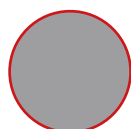

SILVER

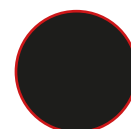

BLACK

## ACCESSORI    ACCESSORIES

Zavorra multiuso di nostra ideazione e produzione, per inserimento asta bandiere. Diametro cm 32, peso 15 Kg.

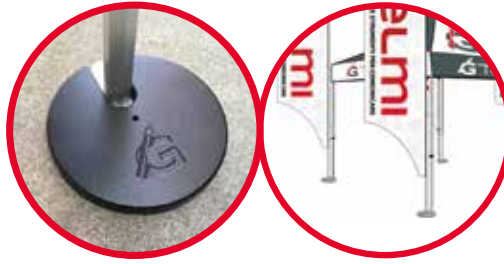

*Our in house designed and produced ballast with incorporated flagpole insertion. Diameter cm 32, weight 15 Kg.*

Pareti laterali interamente personalizzate con stampa monofacciale o bifacciale. Disponibili inoltre pareti neutre senza grafica anche con porta o finestra.



*Fully customizable walls available in either one sided or double faced prints. Also available, basic white walls with a zip-door or window.*

Robusta borsa per il trasporto dei teli.



*A robust bag for transporting wall panels.*

Morsetto per unione di due gazebo per aumentare la stabilità.

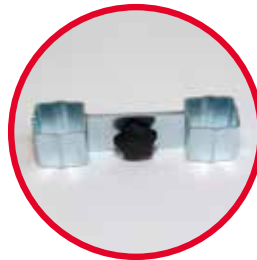

*A practical clamp to join multiple gazebo tents for increased stability.*

Grondaia scoriaacqua posizionabile tra due gazebo.



*A practical gutter that can be installed between multiple gazebo tents.*

Supporto portabandiera da fissare ai montanti della struttura.



*Flag holder for gazebo tent uprights. Double diameter for different sized flag poles.*

**NOVITA'** : Parete in tessuto **HDTEX**.



**NEW:** Wall in **HDTEX** fabric.



## SEDIE PERSONALIZZATE

PERSONALIZED CHAIRS



Solide e robuste hanno la **struttura pieghevole in acciaio**.  
100% Made in Italy.  
Sedute e schienali interamente personalizzati senza limiti di colore o sfumature.  
Leggere, comode e pratiche nel trasporto.

*Solid and strong **folding steel structure**.  
100% made in italy.  
Digitally printed seat and back without any limitations of desired colours or graphics.  
Lightweight, comfortable and easy to transport.*

## TAVOLO PIEGHEVOLE CON TOVAGLIA

FOLDING TABLE WITH TABLECLOTH

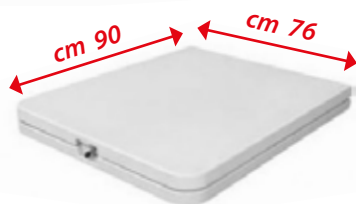
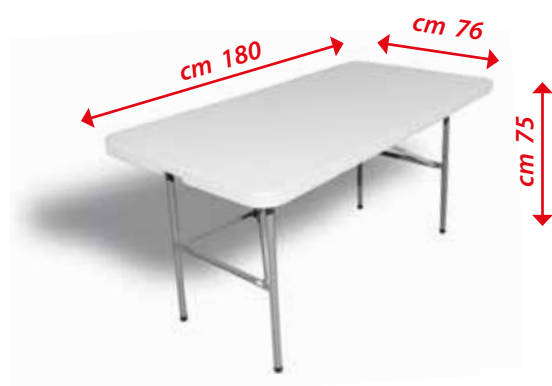

Tavolo pieghevole con ripiano in polipropilene e struttura in ferro zincato.  
Completo di tovaglia classica oppure a cappuccio.

*Folding table with polipropilene top and structure in galvanized iron. Complete with either a traditional or snugly fitting tablecloth.*

# MANGIAINPIEDI

SNACK TABLE



## MAXI version



Dimensions when folded  
cm 82 x 140 x 5



Tavolino con struttura in alluminio e ripiano, dalla linea giovane e dinamica.  
**Rivestito in tessuto lycra stampato in digitale e studiato per esaltarne il design.**

*Snack table made with aluminium frame and top.*

**Covered with digitally printed dye sublimation lycra fabric.**

# BANCHETTO POPUP

POPUP DESK



Struttura in alluminio.  
Ripiani superiore e centrale in legno colore bianco o nero.

*Sturdy aluminium structure.  
Wooden top and center shelf available in either black or white.*



Pratica borsa Trolley per il trasporto.

*Practical trolley for easy transportation.*

Struttura in alluminio che consente una veloce e immediata apertura/chiusura, completa di ripiano centrale. Molto robusta e utilizzabile molte volte. Telo in tessuto stampato in alta risoluzione applicato alla struttura tramite velcro.

**Capiente borsa trolley per il trasporto all'interno della quale inserire anche due roll-up**, per poter creare un pratico allestimento.

*Made from a sturdy aluminium structure with quick and simple setup / removal, complete with a central shelf.*

*Supplied with personalizable high resolution printed fabric with secure velcro attachment. Very robust and durable.*

**Supplied with a capacious trolley which also holds two roll up displays for easy transportation** of a quick and effective display area.

# BANCHETTI

DESKS



## Struttura completamente in alluminio

realizzata all'interno della nostra officina, ripiano in legno, completa di telo in tessuto stampato in alta risoluzione applicabile alla struttura tramite velcro.

Disponibile in 4 versioni:

esagonale, angolare, curva e rettangolare.

Perfetto l'abbinamento coi fondali in alluminio per la creazione di isole promozionali.

## Aluminium structures

made in our in house workshop, complete with wooden top and high definition printed fabric with velcro attachments.

Available in 4 shaped versions:

hexagonal, angular, round and rectangular.

A perfect match for our aluminum backdrop to create promotional corners and booths.



**ESAGONALE**  
**HEXAGONAL**



**CURVO**  
**ROUND**



**SGABELLO**  
**STOOL**



**ANGOLARE**  
**ANGULAR**

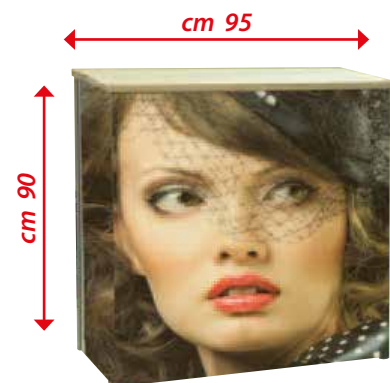

**PICCOLO**  
**SMALL**

**MONTAGGIO FACILE E VELOCE: OCCORRE SOLAMENTE UNA CHIAVETTA ESAGONALE!**

**QUICK AND EASY TO ASSEMBLE WITH JUST A TORX KEY!**





# OMBRELLONI PERSONALIZZATI

CUSTOMIZED BEACH UMBRELLA



## OMBRELLONE CLASSIC

Struttura in acciaio verniciato colore bianco realizzata in Italia. Diametro 22 mm con prolunga 25 mm, bloccaggio con leva. Apertura tramite tasto.

Personalizzazione con tessuto 100% poliestere stampato in digitale sublimatico da carta transfer ad alta definizione con colori brillanti.



## CLASSIC UMBRELLA

White painted steel construction made in Italy. 22 mm diameter with 25 mm extension, locking lever and opening button. Customization with 100% polyester sublimation digital printed fabric from high definition transfer paper with bright colours.

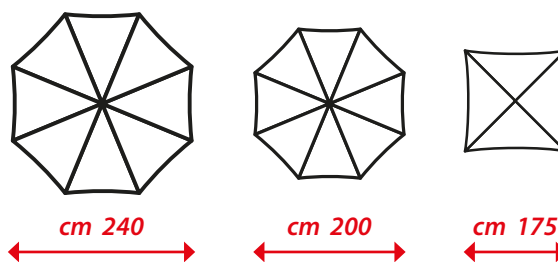

## OMBRELLONE DELUXE

Struttura in alluminio anodizzato realizzata in Italia. Bastone in alluminio da 35 mm rigato ed anodizzato. Prolunga in alluminio da 40 mm rigato ed anodizzato. Bloccaggio centrale a vite. Cappuccio a palla colore bianco. Balene in acciaio zincato.

Personalizzazione con tessuto 100% poliestere stampato in digitale sublimatico da carta transfer ad alta definizione con colori brillanti.

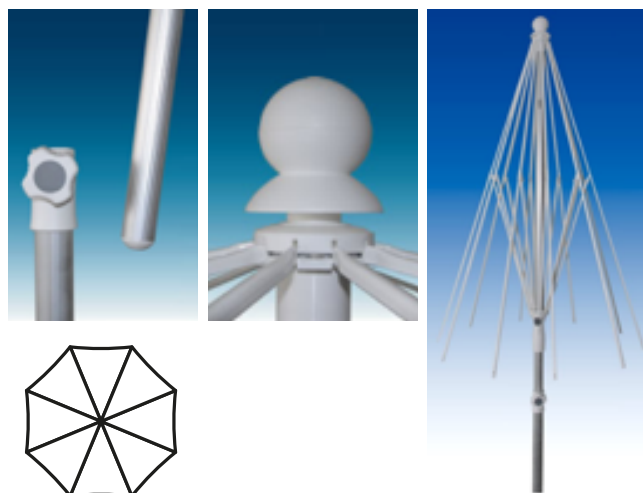

## DELUXE UMBRELLA

Anodized aluminium construction made in Italy. 35 mm striped and anodised aluminium pole. 40 mm ribbed and anodised aluminium extension. Central locking screw. White coloured top cap. Galvanized steel ribs. Customization with 100% polyester sublimation digital printed fabric from high definition transfer paper with bright colours.



**PERFETTO ABBINAMENTO  
CON LE SEDIE PERSONALIZZATE**

**A PERFECT MATCH FOR  
OUR CUSTOMIZABLE CHAIR**



**COMUNICARE  
IN UN'ALTRA  
DIMENSIONE**

**COMMUNICATION  
IN ANOTHER  
DIMENSION.**

**INNOVATIVA LINEA DI PRODOTTI  
GONFIABILI PER TUTTI I TUOI EVENTI  
INDOOR E OUTDOOR**

**INNOVATIVE COLLECTION OF  
INFLATABLES FOR YOUR INDOOR AND  
OUTDOOR EVENTS**



**X GLOO**  
SHAPING AIR

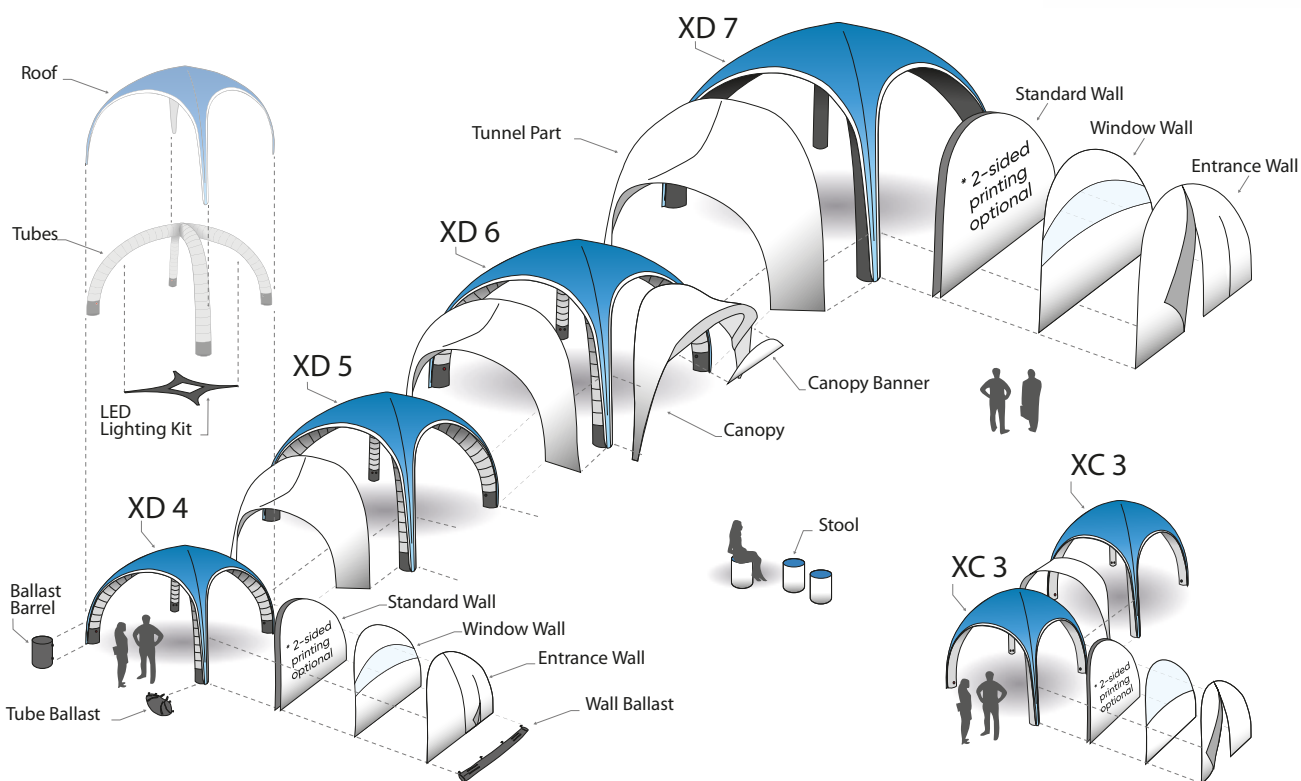

**Misure disponibili**  
*Available sizes*

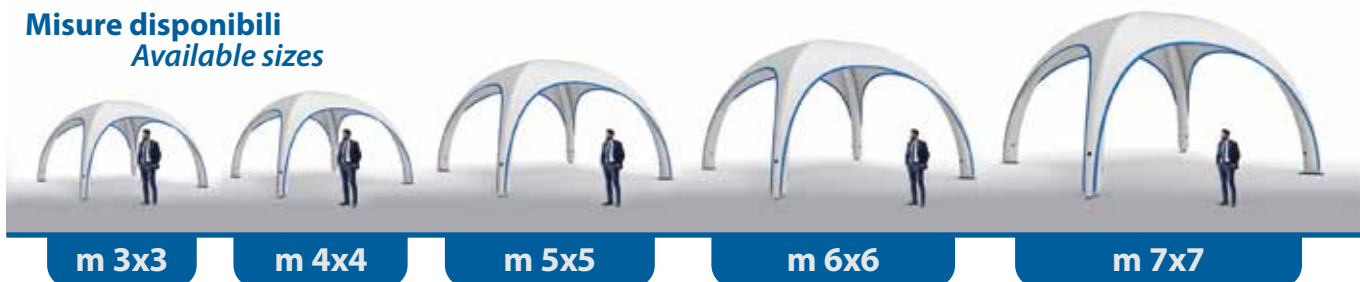

 **reddot design award**  
winner



**PRINTABLE**



**MODULAR**



**QUICK SETUP**



**EASY TO USE**



**VERSATILE**



**ALL TERRAIN**



**WATER PROOF**



**UV RESISTANT**



**FLAME  
RETARDANT**



**WIND  
RESISTANT**



**PREMIUM  
QUALITY**

Nuovo sistema di gonfiaggio che permette di gonfiare contemporaneamente le quattro gambe. Accessorio opzionale.

*New inflation system that allows simultaneous inflation of all four legs. Optional accessory.*



**ONE-PUMP  
INFLATION**

Utilizzo di tessuti e materiali selezionati con classificazione ignifuga, per utilizzo sia all'interno che all'esterno.

Made from selected fireproof fabrics and materials, for both indoor and outdoor use.



Fissaggio del tetto alle gambe gonfiabili, per una facile e veloce sostituzione del tetto in caso di nuova grafica.

Attachment of the roof to the inflatable legs, allows for quick and easy replacement of the roof in case of new graphics.



Ganci robusti per il fissaggio tramite picchetti o zavorre, se correttamente ancorato il gonfiabile può resistere a venti di 60 km/h.

Sturdy hooks for fixing with pegs or ballasts, When properly anchored the structure can withstand winds up to 60 km/h.











## TOTEM GONFIABILE

INFLATABLE TOTEM



Base zavorrata  
con ruote.

*Ballast base  
with wheels.*

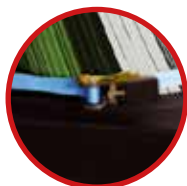

Cinghia di sicurezza  
con cricchetto.

*Safety strap  
with ratchet.*

Totem gonfiabile interamente personalizzato. Completo di motore elettrico e luce interna per illuminare il telo.

Per l'utilizzo non occorrono i tiranti **visto che la base, avete un peso di 65 Kg, rappresenta di per sé la zavorra** necessaria per utilizzare il gonfiabile anche in ambienti esterni. Il totem può essere spostato con notevole facilità grazie alle ruote.

Disponibile nelle altezze cm 300, cm 400 e cm 500.

*Fully customizable inflatable totem.*

*Complete with integrated electric motor and light to illuminate the printed fabric.*

**The robust base weighing 65 kg means guide ropes are not necessary even when used outdoors.**

*Built in wheels make moving the totem easy. Available in the following heights 300 cm, 400 cm and 500 cm.*

## CILINDRI GONFIABILI PER EVENTI

INFLATABLE EVENT CYLINDERS



Telo con stampa in digitale a più colori e immagini, facilmente intercambiabile.

Completati di basamento con motore elettrico, corde, picchetti e borsa per il trasporto.

Ingombro e peso ridotti per una maggiore facilità di trasporto.

Disponibili nella versione dritta oppure sagomata.

*Fully customizable and easily interchangeable multi-coloured printed fabric. Comes complete with an integrated electric motor in the base, guide ropes, pickets and carry bag. Compact size and weight for easy transportation.*

*Available in both straight or shaped versions.*



# ARCO GONFIABILE

INFLATABLE ARCH

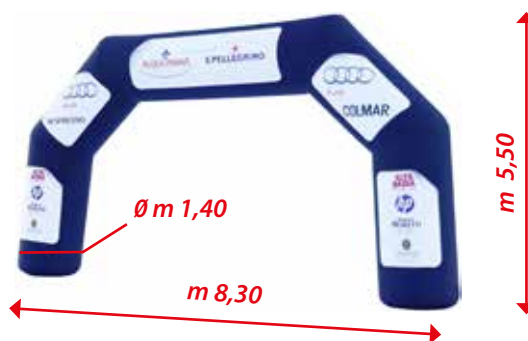
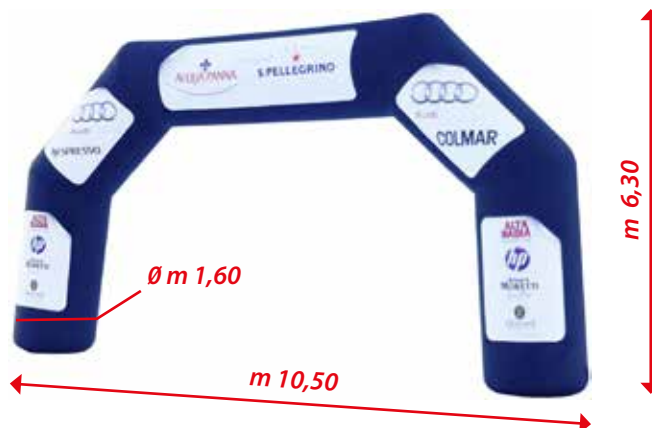

Arco gonfiabile disponibile nella versione FULL PRINT completamente stampato o nella versione tinta unita con teli personalizzati fissati tramite velcro.

Stampa in digitale HD a più colori e immagini.

Dotato di ventilatore interno ad alte prestazioni realizzato in Italia. Struttura rinforzata antiurto.

**Caratteristiche del nostro motore:** bassi consumi 260W, rumorosità contenuta a 57DBA, peso ridotto a 9 kg. Completo di borsa per il trasporto e funi di ancoraggio.

*Inflatable arch in both FULL PRINT or single colour options, also available with removable velcro pannells.*

*High definition digital printing with multiple colours and graphics.*

*Complete with fully integrated Italian made internal high performance electric fan.*

*Reinforced shock-resistant structure.*

**Electric motor details:** low consumption 260W, noise level 57DBA, weight 9 kg.

*Complete with guide ropes and carry bag for transportation.*

## DISPONIBILI ANCHE NELLA VERSIONE MEZZO ARCO E ARCO CURVO

ALSO AVAILABLE IN HALF ARCH AND CURVED ARCH VERSIONS

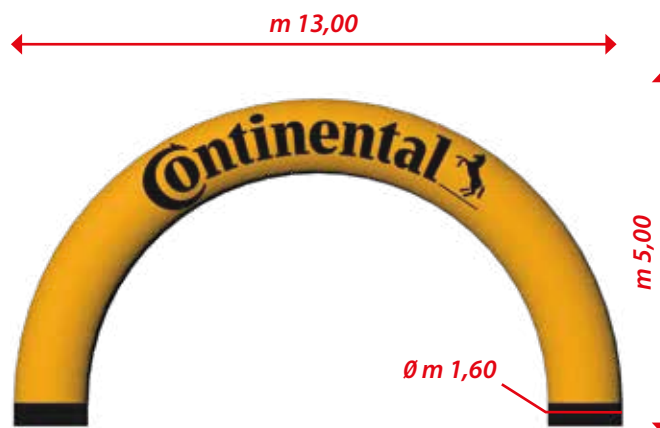
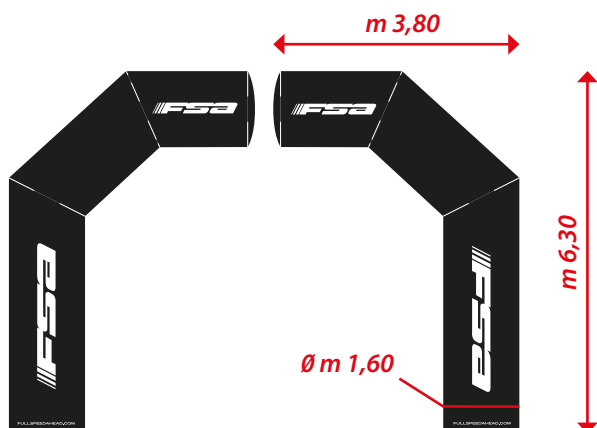



## TAPPETO PESANTE

HEAVY DUTY MATS



**PRODOTTO ESCLUSIVO INTERAMENTE  
REALIZZATO NELLA NOSTRA TESSITURA**

**PERSONALIZZATO  
NELLE DIMENSIONI E NELLE GRAFICHE**

**STUDIATO PER GARANTIRE UN'ELEVATA RESISTENZA  
ALLO SFREGAMENTO E ALL'USURA NEL TEMPO.**

**PESO 1200 gr/m<sup>2</sup>**

**EXCLUSIVE PRODUCT  
MANUFACTURED ENTIRELY IN HOUSE**

**PERSONALIZED SIZES  
AND GRAPHICS**

**DESIGNED TO ENSURE HIGH FRICTION  
AND WEAR RESISTANCE OVER TIME.**

**WEIGHT 1200 gr/m<sup>2</sup>**



**Bordatura perimetrale  
di rinforzo.**  
*Reinforced edges.*

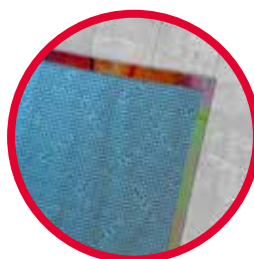

**Retro con gommatura antiscivolo  
per la massima sicurezza.**

*Skidproof rubber lining on the  
underside for maximum security.*

# TAPPETO GOMMATO

RUBBERIZED MAT



**Tessuto gommato da noi ideato e realizzato.**  
Garanzia di durata nel tempo.  
Completamente personalizzato  
nella stampa e nelle dimensioni.

**Rubberized fabric designed  
and manufactured in house.**  
Long-life guarantee.  
Fully customizable size and printing.

**Bordatura perimetrale per una  
maggiore eleganza del prodotto.**

*Detailed edges  
for added elegance.*



**Retro con gommatura antiscivolo  
per la massima sicurezza.**

*Skidproof rubber lining on the  
underside for maximum security.*





## SACCO POUFF

POUFF BAGS



Comode sedute interamente personalizzate, riempite con microsfere di polistirolo di alta qualità e indeformabili. Adatte per allestimenti e come **elemento d'arredo sia all'interno che all'esterno.**

Fully customizable comfortable seating, filled with high quality polystyrene microspheres. **Ideal for both decoration and as functional furniture for both indoor and outdoor use.**

## MESSAGGI PUBBLICITARI 3D

3D ADVERTISING

Realizzati in tessuto ignifugo e stampa ad alta risoluzione. Imbottiti con microsfere di polistirolo di alta qualità, sono **studiati ad-hoc in base alle vostre esigenze.** Ideali per allestimenti di punti vendita, fiere ed eventi, sia indoor che outdoor.

Made from fireproof fabrics with high definition graphics. Filled with polystyrene microspheres, **ad-hoc shapes and designs available based on individual requirements.** An original and unique solution for stores, exhibitions and events.



## CUSCINO

CUSHION



Ideale in ogni ambiente, di impatto ovunque si metta, il nostro cuscino è personalizzato su entrambi i lati. **Disponibile con imbottitura sottovuoto per facilitare il trasporto.**

Perfect for every situation! Customizable on both sides. **Can be supplied vacuum packed for easy shipping.**



## POLTRONA POUFF

### POUFF CHAIR



Perfetto l'abbinamento coi dadi pouff per la creazione di aree relax



Together with the pouff cube it makes a perfect combination for relax areas

**Interamente personalizzata** senza limiti di colore e immagini. Interno in gommapiuma ad alta densità per una perfetta comodità di seduta. Sfoderabile per un cambio della personalizzazione o un facile lavaggio.

**Fully customizable**, no limits to the number of colours or graphical designs.

Made from high density foam for comfort.

Removable cover for a change of design or for easy washing.

## DADO POUFF

### POUFF CUBE



**Interno in gommapiuma ad alta densità per una perfetta comodità di seduta indeformabile.** Fodera personalizzata su tutti i lati in tessuto elastico che si adatta perfettamente all'imbottitura, senza lasciare pieghe. Sfoderabile per un facile lavaggio o cambio della personalizzazione.

**Made from high density foam for comfort.**

Personalize all sides of the stretch fabric cover which fits perfectly without any creases.

Removable for easy cleaning or change of design.

## CUSCINO PER SEDUTE

### SITTING CUSHION



Personalizzato su entrambi i lati.  
Ideale per punti vendita, stadi, teatri, congressi.

Customizable on both sides.

Ideal for stores, stadiums, theaters and conventions.

# STENDARDI / POSTER

KAKEMONO / POSTER



Stampa in digitale ad alta risoluzione senza limiti di colore o sfumature. A disposizione una vasta collezione di tessuti per ogni esigenza. Personalizzabile in ogni formato.

**Ottima soluzione per comunicazione visiva indoor,** ideale per punti vendita ed esposizioni. Disponibili soluzioni diverse per l'appenditura.

*High resolution digital printing with no limits to the number of colours or designs. An extensive selection of fabrics to choose from for every occasion.*

*Total freedom of shape and design.*

**An excellent solution for indoor visual communication,** ideal for stores and exhibitions.

*Different hanging solutions to choose from.*

Tubicino con cordino per appenditura.

*Tube insert with a lanyard for hanging.*





## SCIARPE E FOULARD

SCARVES AND FOULARD



**Il classico gadget rivisto in digitale**, realizzato senza limiti di quantità e personalizzazione, grazie alla stampa digitale. Il processo di stampa garantisce la migliore solidità del colore, fondamentale per i prodotti a contatto con la pelle. La confezione è sartoriale e curata nei minimi particolari.

*Thanks to **digital printing technology** there are no minimum quantities or limits to the number of colours that can be used. The printing process ensures the fixing of the colours, an essential requirement for products worn next to the skin. Sartorial finish with great attention to detail.*

## TENDE

CURTAINS



Personalizzabili con immagini, loghi aziendali e sociali, e ogni tipo di messaggio pubblicitario.

Realizzati in digitale senza limiti di colore e sfumature.

**Prodotte su misura e confezionate in base alle esigenze del cliente con cura sartoriale.**

Disponibili nella versione a pannelli o tenda da camerino in tessuto oscurante.

*Totally customizable with no limits to the number of colours or graphics, ideal for advertising messages, company and brand logos.*

**Tailored and packaged according to individual customer requirements.**

*Available in panel or curtain formats and also as changing room curtains made with blackout fabric.*

## TOVAGLIE

TABLECLOTHS



Completamente personalizzabili nella stampa e nelle dimensioni, sia nella versione tradizionale che nella versione a cappuccio.

**Disponibili in differenti tessuti in base alle esigenze del cliente.**

*Fully customizable designs and sizes. Available in both traditional and close fitting versions.*

**Available in different fabrics based on customer requirements.**



Il panno al servizio della tecnologia.

**L'Unico, Vero, Originale.**

**A COSA SERVE?**

Serve per pulire tutti gli apparecchi "touch", smartphone, tablet, computer, monitor, telefonini, occhiali, vetri...

**PERCHÉ GADGET?**

Perché si può personalizzare con loghi o immagini, un gadget utile ed economico.

Dimensioni standard:  
cm 15x20 e cm 20x30.

Disponibilità di differenti imballi:  
cubetto personalizzato in cartone,  
cubetto in plastica semitrasparente,  
imbusto singolo.

*Cleaning cloth for tech devices.*

***The one and only, the original.***

***WHAT IS IT?***

*A microfiber cloth for cleaning all kinds of "touchscreen" devices, smartphones, tablets, computers, monitors, cellphones, glasses, windows...*

***SINCE WHEN IS IT A GADGET?***

*Now it can be customised with your own logos and graphics, it's the perfect practical and cost effective gadget.*

*Standard sizes available:  
15x20 cm and 20x30 cm.*

*Several packaging solution to choose from:  
Customized cardboard cube,  
Translucent plastic cube,  
Individually wrapped.*



# SALVIETTE

## PERSONALIZED TOWELS



Salvietta in spugna da 400 gr/m<sup>2</sup>,  
50% cotone 50% poliestere.  
Stampa in digitale sublimatico da carta transfer  
ad alta definizione con colori brillanti.  
Solidità del colore garantita, fondamentale per prodotti a  
contatto con la pelle.

*Soft towels made from 400 gr/m<sup>2</sup>,  
50% cotton 50% polyester.  
Sublimated high definition digital printing from paper  
transfer with brilliant colours.  
Guaranteed colour fixing, essential for products used in  
contact with the skin.*

### SALVIETTE STANDARD

Dimensioni cm 80x50 - 100x50 - 180x80  
o personalizzabili.

### STANDARD TOWELS

Sizes 80x50 cm - 100x50 cm - 180x80 cm .  
Can also be made to measure.



### SALVIETTE GOLF

Complete di occhiello e moschettone per un pratico  
utilizzo. Stampa digitale con vostri loghi o immagini.  
Dimensioni cm 15x50.

### GOLF TOWELS

*Complete with metal eyelet and practical hinged hook. Can  
be digitally printed with your logos or graphics.  
Folded size 15/50 cm .*









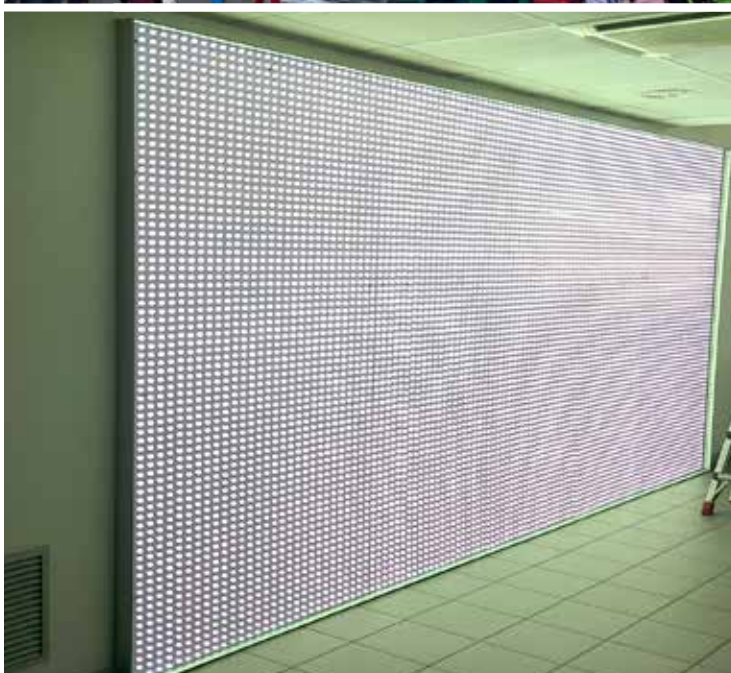





















SUPPLIER OF  
BANNERS FOR



BROOKLIN LONDON BARCELLONA MILANO

















**Tessitura  
F.lli Gelmi S.r.l.**

Via dei Mulini, 5  
24026 Leffe (BG) - ITALY  
Tel. +39 035.732339  
Fax +39 035.732084  
[info@tessituragelmi.it](mailto:info@tessituragelmi.it)  
[www.tessituragelmi.it](http://www.tessituragelmi.it)

